

www.kggfa.com
www.kgg-robot.com



KGG

KGG

传动领域的“智”“惠”“加”
控制系统的指挥家

Expert but with Excellent cost performance in Smart
transmission and Precise control system.

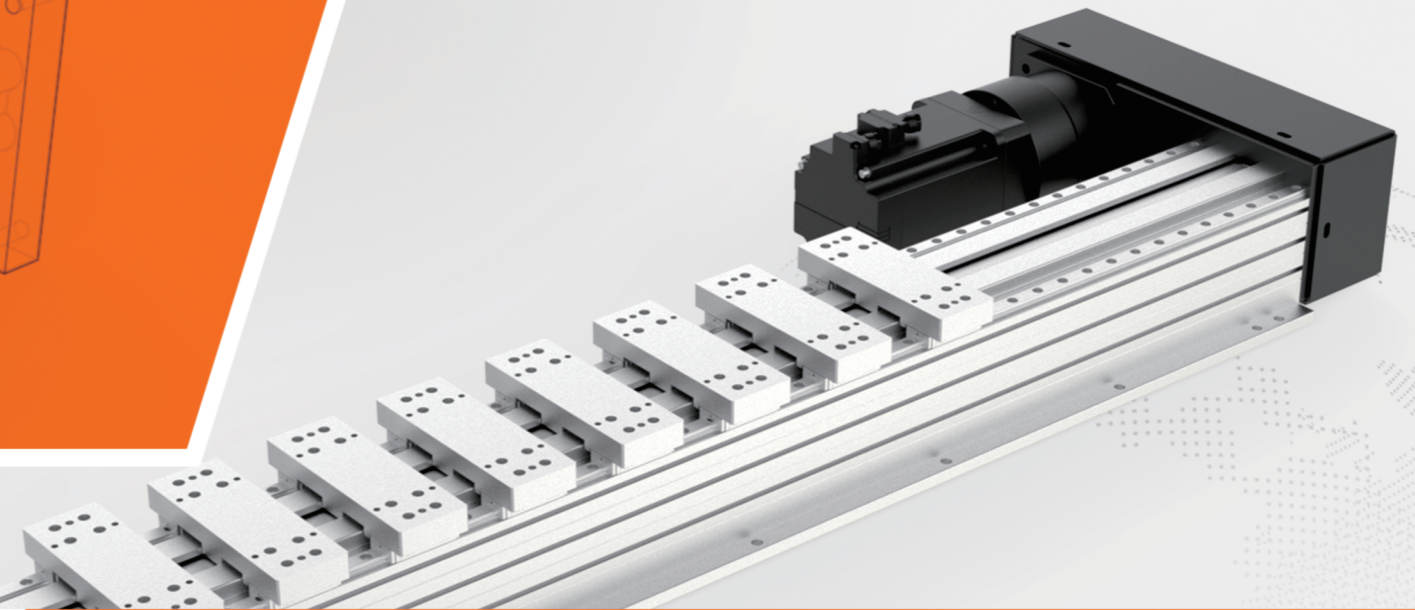
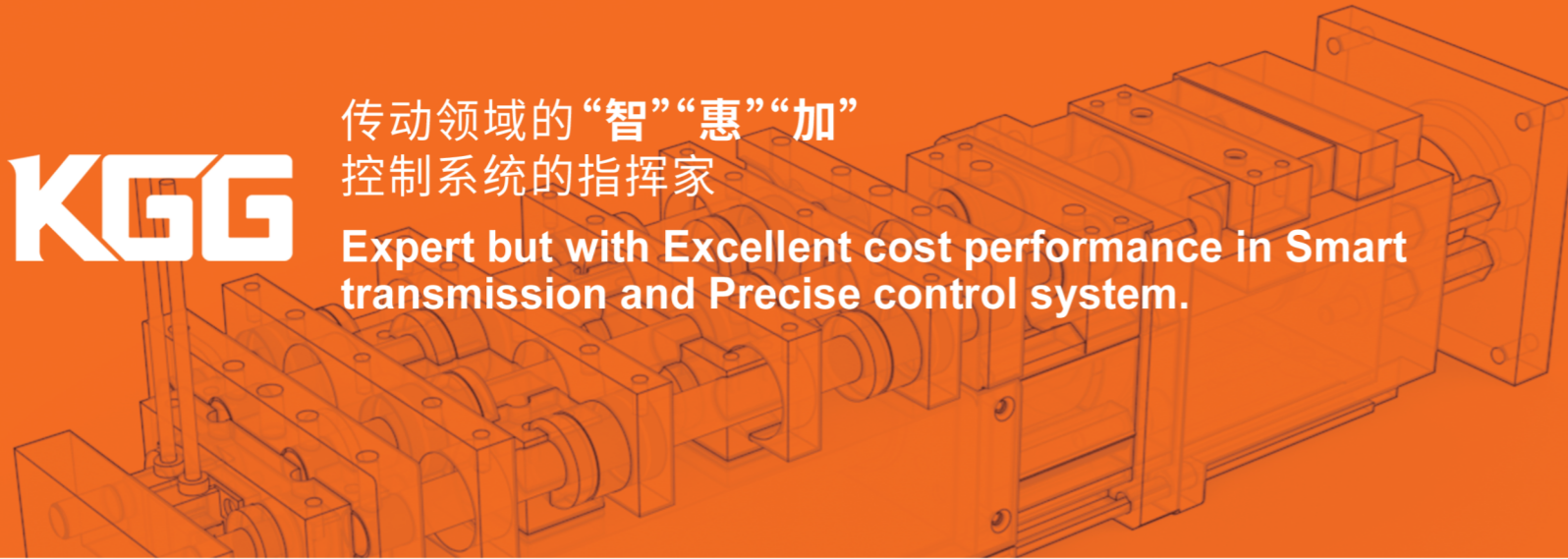

高精度/高速度/安装简易
High precision/High speed/Easy installation

上海狄兹精密机械有限公司
Shanghai Dizi Precision Machinery Co.,Ltd.

电话: 021-51872555
邮箱: amanda@kgg-robot.com
网址: www.kggfa.com/www.kgg-robot.com
地址: 上海市松江区港德路188号

Tel: 021-51872555
Mail: amanda@kgg-robot.com
Website: www.kggfa.com/www.kgg-robot.com
Address: No.188, Gangde Road, Songjiang
District, Shanghai

上海凯吉集机器人有限公司
Shanghai KGG Robots Co.,Ltd.



3D选型软件
3D Selection
Software

**PT SERIES VARIABLE
PITCH SLIDING TABLE**

PT系列变距滑台

PT Series

变距滑台

高精度/高速度/安装简易

High Precision/High Speed/Easy Installation

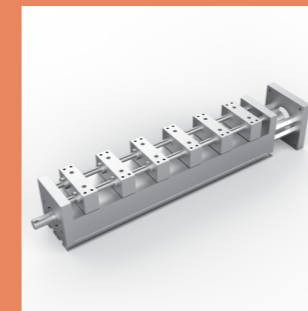
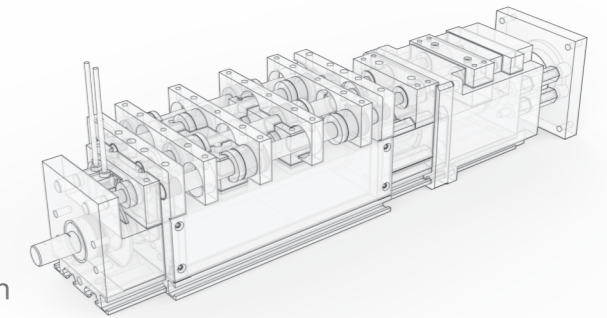

PT50 型 Type

本体宽度 50mm
Body Width
本体最大长度 330mm
Maximum Length of Body
滑块最多个数 16个
Maximum Number of Sliders
变距范围 9-90mm
Variable Distance Range

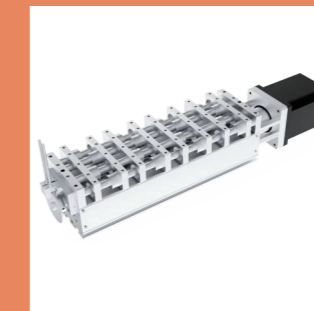

PT70 型 Type

本体宽度 70mm
Body Width
本体最大长度 380mm
Maximum Length of Body
滑块最多个数 16个
Maximum Number of Sliders
变距范围 9-90mm
Variable Distance Range



PT100 型 Type

本体宽度 111mm
Body Width
本体最大长度 2060mm
Maximum Length of Body
滑块最多个数 32个
Maximum Number of Sliders
变距范围 42-118mm
Variable Distance Range



PT120 型 Type

本体宽度 155mm
Body Width
本体最大长度 3140mm
Maximum Length of Body
滑块最多个数 36个
Maximum Number of Sliders
变距范围 60-180mm
Variable Distance Range

PT系列/Series



50-155MM
本体宽度/Body Width

330-3140MM
本体最大长度
/Maximum Length Of Body

16-36个
滑块最多个数
/Maximum Number Of Slider

任意变距示意

/ Illustration Of Arbitrary Variable Distance

- 01.可任意变距置换。
- 02.可将相同间距的物品依次放入不同间距的托盘/输送带/包装盒及测试治具等。

01. It can be changed at any distance.
02. The same spacing of items can be put into different spacing of pallets/conveyors/boxes and testers etc.

结构优势

/ Structural Advantages

- 维护及组装方便。
- 缩短工时设计与安装。
- 高精度变距高速长时间稳定运行操作。

Easy maintenance and assembly.
Reduced man-hours design and installation.
Highly accurate variable pitch high speed long and stable operation.

马达安装样式

/ Motor Mounting Style



变距范围

/ Variable Distance Range

- PT50: 9-90MM
- PT70: 9-90MM
- PT100: 42-118MM
- PT120: 60-180MM

PT50 高精度/高速度/安装简易
High Precision/High Speed/Easy Installation



本体宽度 Self Width	50 mm	本体最长长度 Maximum Length Of Body	330 mm	滑块最多个数 Maximum Number Of Sliders	16 ↑	变距范围 Variable Pitch Range	9-90 mm
--------------------	-------	----------------------------------	--------	-------------------------------------	------	------------------------------	---------

型号表示方式 Ordering Method

PT50 - H2 - 9 - 90 - M - NL - ST60 - L - MN5 - 001 - □□

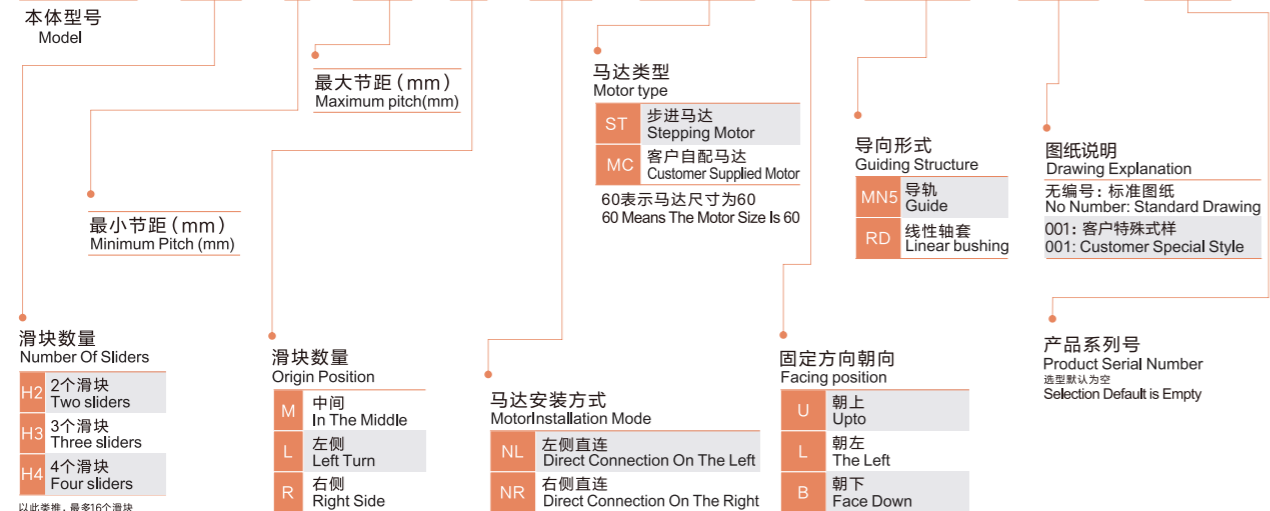

技术参数 Technical Parameter

规格 Spec	本体最长长度(mm) Maximum Length Of Body(mm)	130				250				330			
	滑块最多个数 Maximum Number Of Sliders	2	3	4	5	6	7	8	9	10	12	14	16
	变距范围(mm) Pitchrange	9~90	9~41	9~30	9~23	9~42	9~35	9~30	9~26	9~32	9~26	9~22	9~19
	重复定位精度(mm) Repeatability(mm)	±0.025								±0.045			
	定位精度(mm) Positioning Accuracy(mm)	±0.05								±0.1			
	滑块高度变化(mm) Slider Height Change	±0.1 (标准尺寸) (Regular size)								±0.15 (标准尺寸) (Regular size)			
	驱动方式 Drivemethod	外部输入(马达可选) External Input (Motor optional)								外部输入(马达可选) External Input (Motor optional)			
	额定扭矩(N·m) Rated Torque(n·m)	0.5以上 over								0.5以上 over			
最大使用频率 Maximum Frequency Of Use	100CPM								100CPM				
适用温度 Applicable Temperature	10~40℃								10~40℃				
部件 Parts	感应器外挂 Home Sensor Outside	可选 optional								可选 optional			
	润滑 Lubricating	润滑脂 Lubricating Grease								润滑脂 Lubricating Grease			
	电机型号 Motor Model	40电机 Motor								60电机 Motor			

悬置物 Suspension

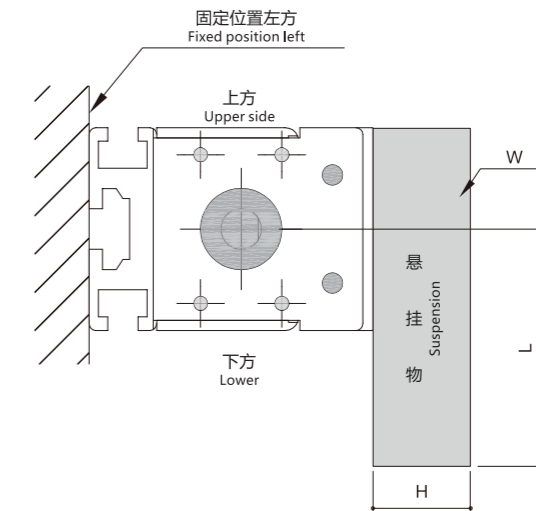

W	单头负载 Single head load
H	单头悬置物的宽度 Width of single head suspension
L	单头悬置物的长度 Length of single head suspension

位移时间和负载能力 Displacement Time And Load Capacity

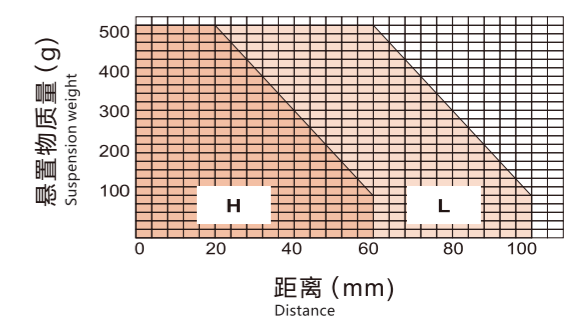
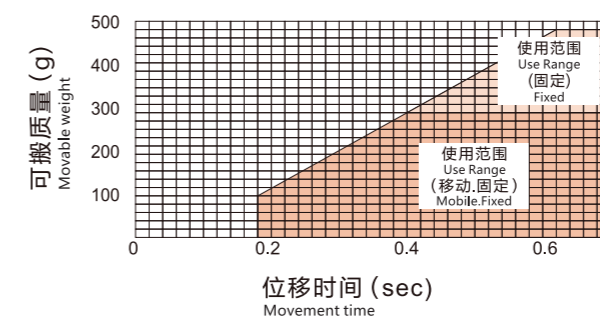

PT50

标准出轴心
Standard out axis

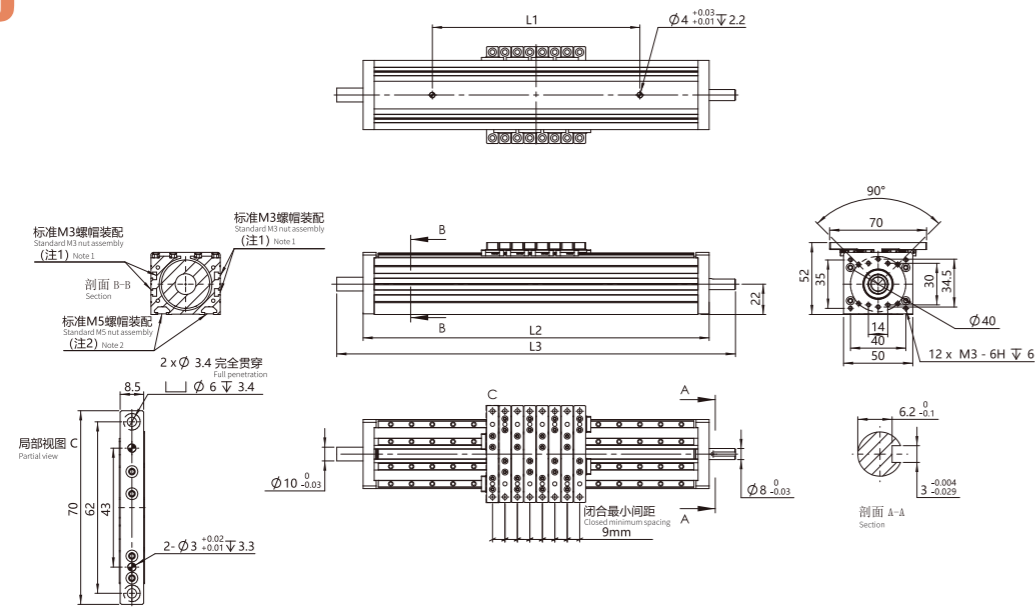

本体长度 (mm) Body Length	L1	L2	L3
130	100	130	160
250	150	250	280

PT50-NL

马达左折
Motor left fold

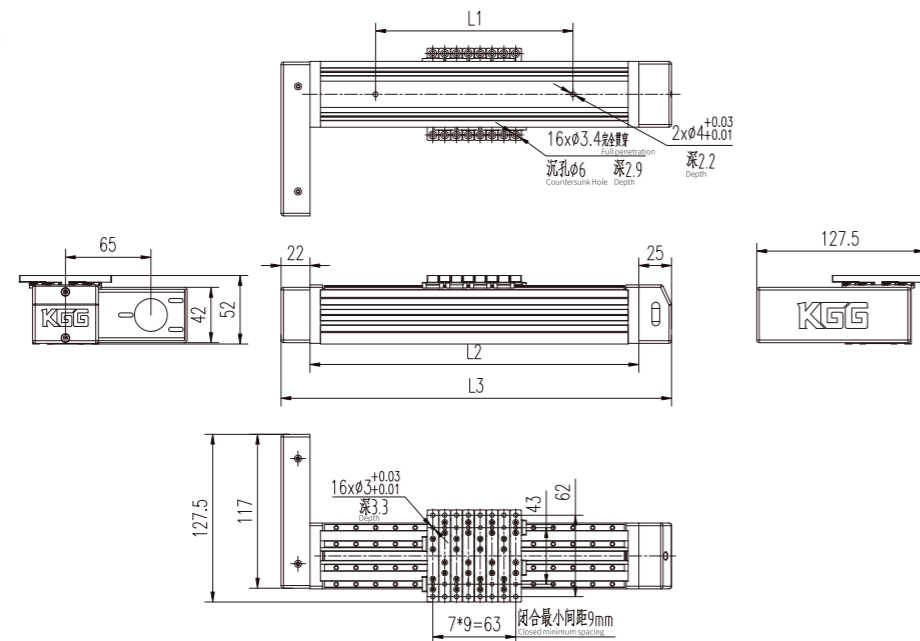

本体长度 (mm) Body Length	L1	L2	L3
130	100	130	177
130	100	130	177
330	250	330	377

PT50-NR

马达右折
Motor folding right

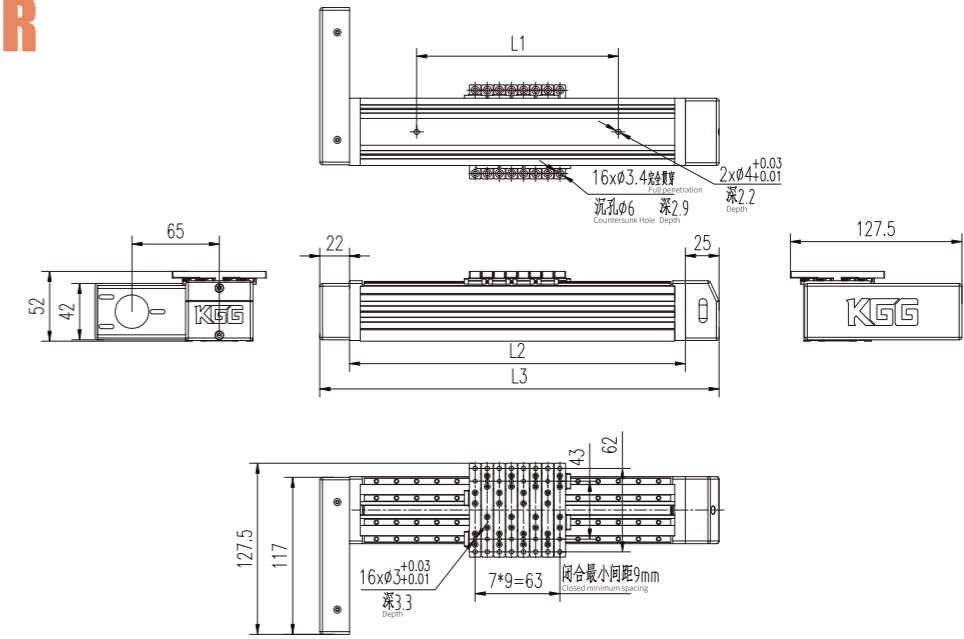

本体长度 (mm) Body Length	L1	L2	L3
130	100	130	177
250	150	250	297
330	250	330	377

PT70 高精度/高速度/安装简易
High Precision/High Speed/Easy Installation

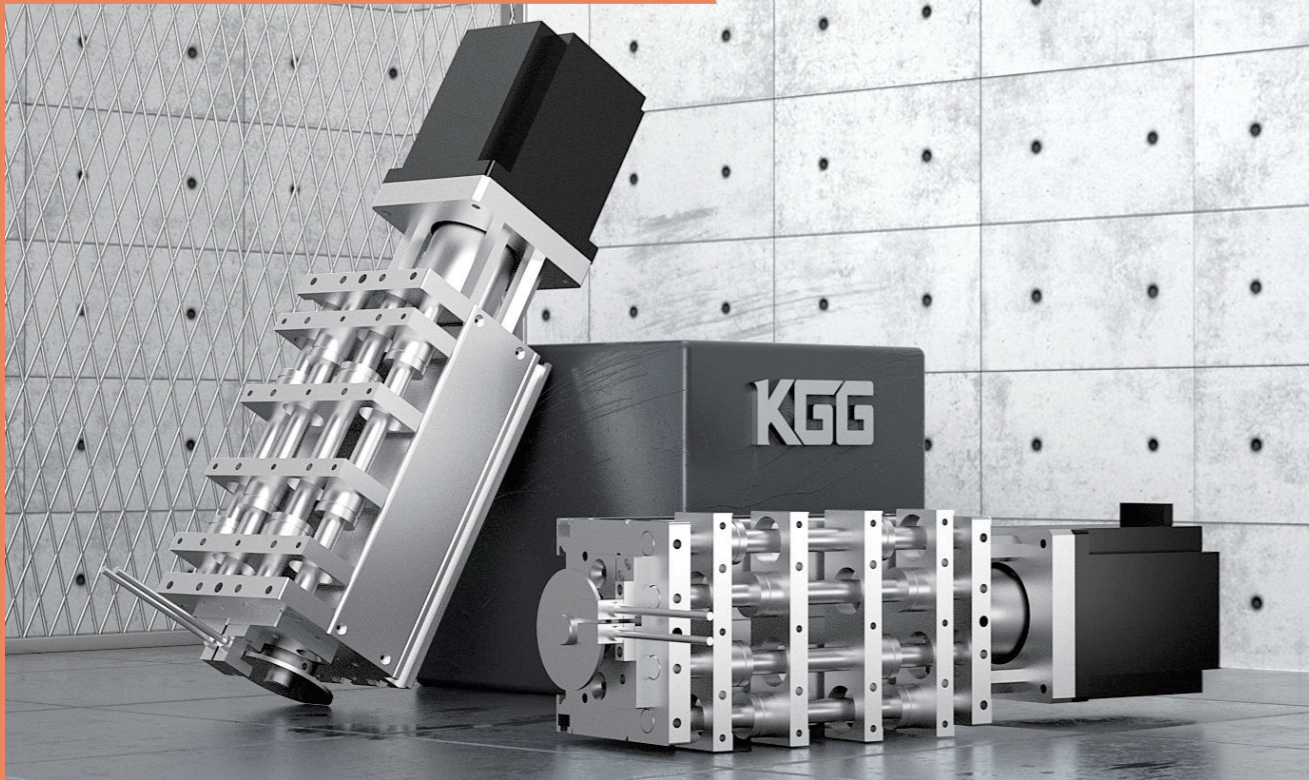

本体宽度 Self Width	70 mm	本体最长长度 Maximum Length Of Body	380 mm	滑块最多个数 Maximum Number Of Sliders	16 ↑	变距范围 Variable Pitch Range	9-90 mm
--------------------	-------	----------------------------------	--------	-------------------------------------	------	------------------------------	---------

型号表示方式 Ordering Method

PT70-H2-9-90-M-NL-ST60-L-MN5-001-□□

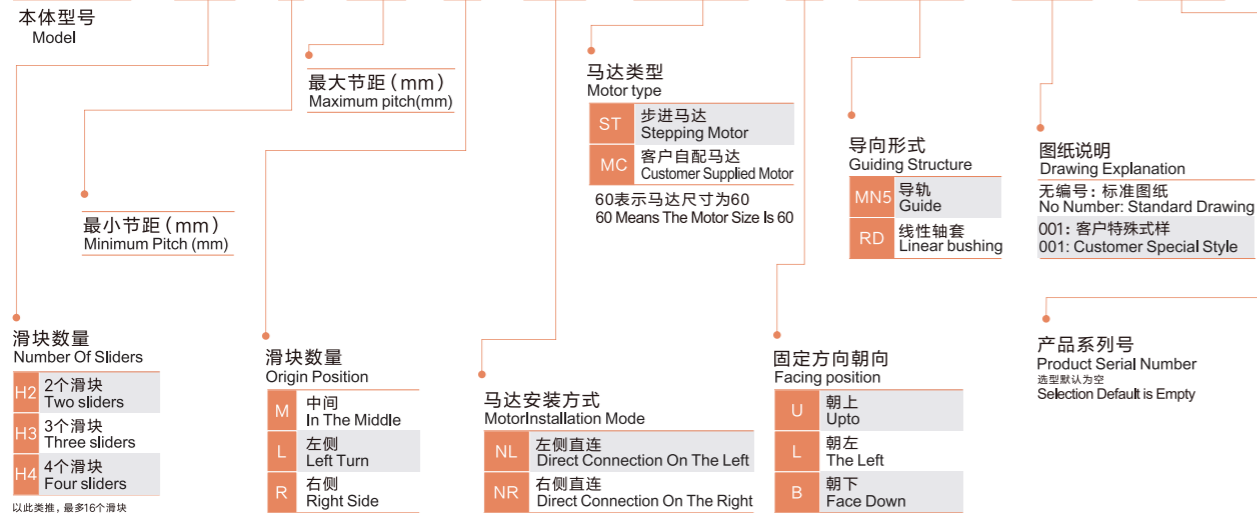

技术参数 Technical Parameter

规格 Spec	本体最长长度(mm) Maximum Length Of Body(mm)	135				255				380			
	滑块最多个数 Maximum Number Of Sliders	2	3	4	5	6	7	8	9	10	12	14	16
	变距范围(mm) Pitchrange	9~90	9~41	9~30	9~23	9~42	9~35	9~30	9~26	9~37	9~30	9~25	9~22
	重复定位精度(mm) Repeatability(mm)	±0.025								±0.045			
	定位精度(mm) Positioning Accuracy(mm)	±0.05								±0.1			
	滑块高度变化(mm) Slider Height Change	±0.1 (标准尺寸) (Regular size)								±0.15 (标准尺寸) (Regular size)			
	驱动方式 Drivemethod	外部输入(马达可选) External Input (Motor optional)											
	额定扭矩(N·m) Rated Torque(n·m)	0.5以上 over											
最大使用频率 Maximum Frequency Of Use	100CPM												
适用温度 Applicable Temperature	10~40℃												
部件 Parts	感应器外挂 Home Sensor Outside	可选 optional											
	润滑 Lubricating	润滑脂 Lubricating Grease											
	电机型号 Motor Model	60电机 Motor											

悬置物 Suspension

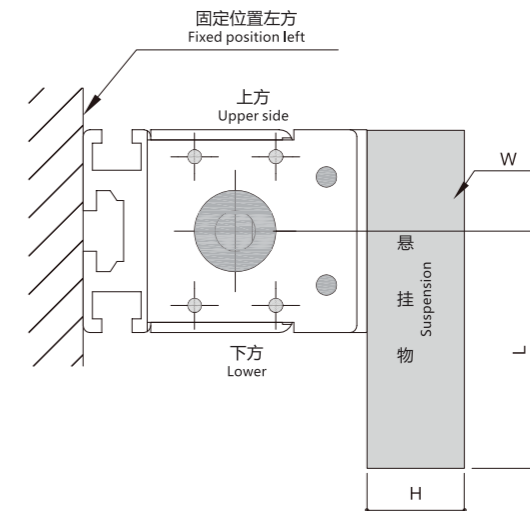

W	单头负载 Single head load
H	单头悬置物的宽度 Width of single head suspension
L	单头悬置物的长度 Length of single head suspension

位移时间和负载能力 Displacement Time And Load Capacity

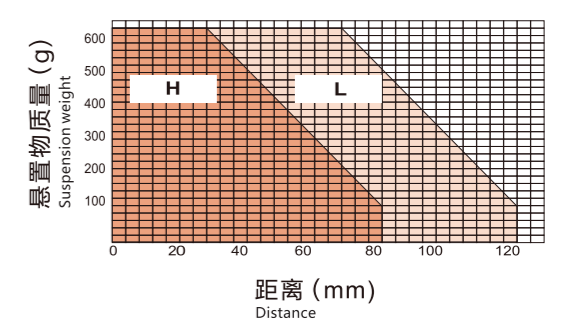
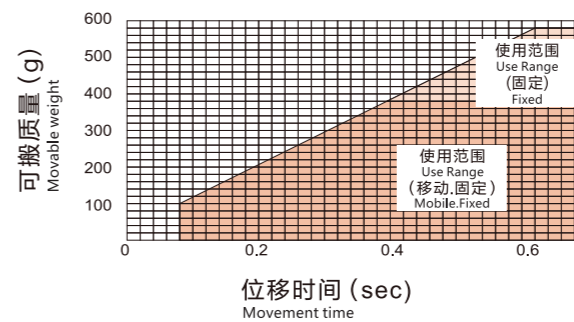

PT70

标准出轴心
Standard out axis

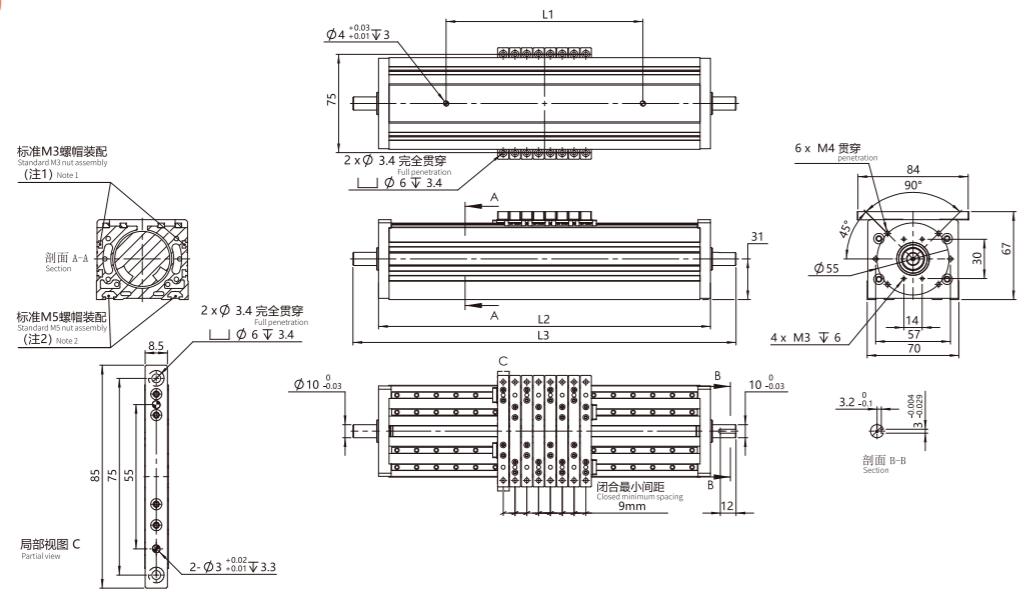

本体长度 (mm) Body Length	L1	L2	L3
135	100	135	165
255	150	255	285

PT70 -NL

马达左折
Motor left fold

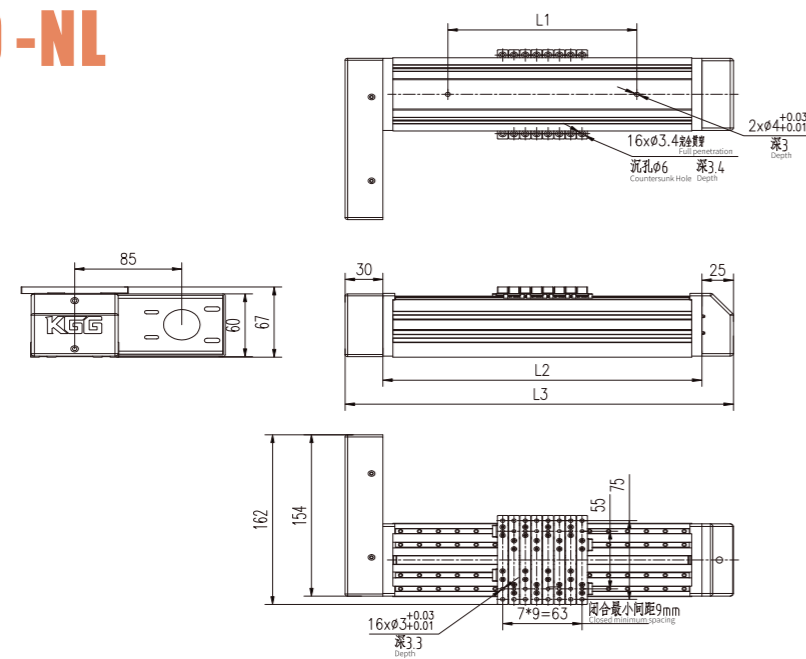

本体长度 (mm) Body Length	L1	L2	L3
135	100	135	190
253	150	253	308
380	300	380	435

PT70 -NR

马达右折
Motor folding right

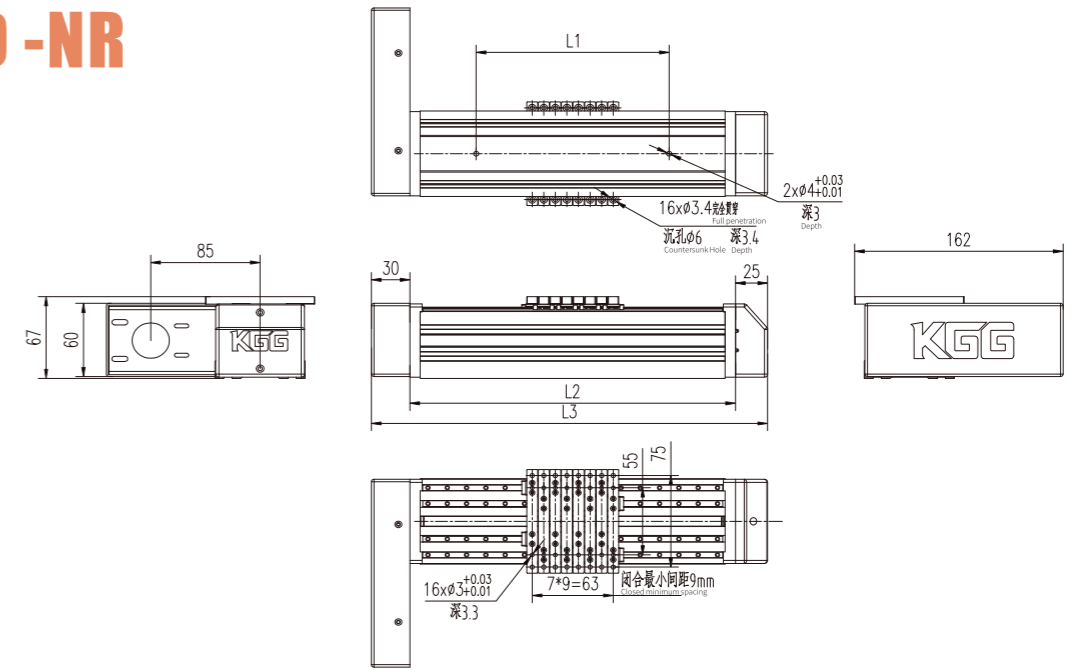

本体长度 (mm) Body Length	L1	L2	L3
135	100	135	190
253	150	253	308
380	300	380	435

PT100 高精度/高速度/安装简易
High Precision/High Speed/Easy Installation



本体宽度 Self Width	111 mm	本体最长长度 Maximum Length Of Body	2060 mm	滑块最多个数 Maximum Number Of Sliders	32 ↑	变距范围 Variable Pitch Range	42-118 mm
--------------------	--------	----------------------------------	---------	-------------------------------------	------	------------------------------	-----------

型号表示方式 Ordering Method

PT100-H8-42-118-M-NL-ST60-L-MN5-001-□□

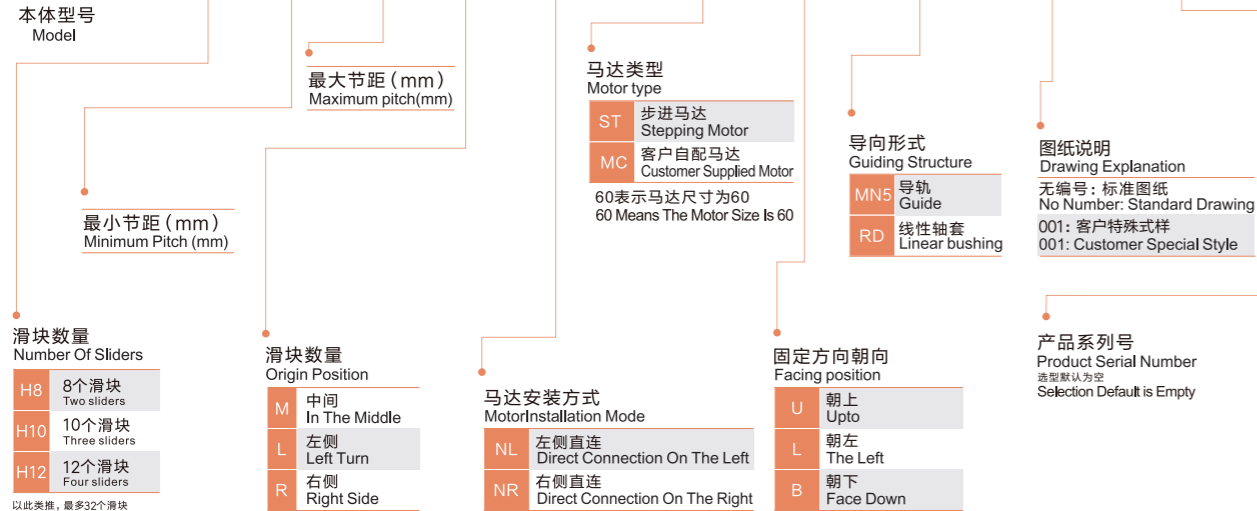

技术参数 Technical Parameter

规格 Spec	本体最长长度(mm) Maximum Length Of Body(mm)	940			1490			2060	
	滑块最多个数 Maximum Number Of Sliders	8	10	12	16	20	24	28	32
	变距范围(mm) Pitchrange	42~118	42~92	42~75	42~134	42~73	42~60	42~70	42~63
	重复定位精度(mm) Repeatability(mm)	±0.04			±0.12			±0.20	
	定位精度(mm) Positioning Accuracy(mm)	±0.08			±0.25			±0.40	
	滑块高度变化(mm) Slider Height Change	±0.15 (标准尺寸) (Regular size)							
	驱动方式 Drivemethod	外部输入(马达可选) External Input (Motor optional)							
	额定扭矩(N·m) Rated Torque(n·m)	0.5以上 over							
	最大使用频率 Maximum Frequency Of Use	100CPM							
	适用温度 Applicable Temperature	10-40℃							
部件 Parts	感应器外挂 Home Sensor Outside	可选 optional							
	润滑 Lubricating	润滑脂 Lubricating Grease							
	电机型号 Motor Model	400W+减速机 (马达可选) Reducer (motor optional)							

悬置物 Suspension

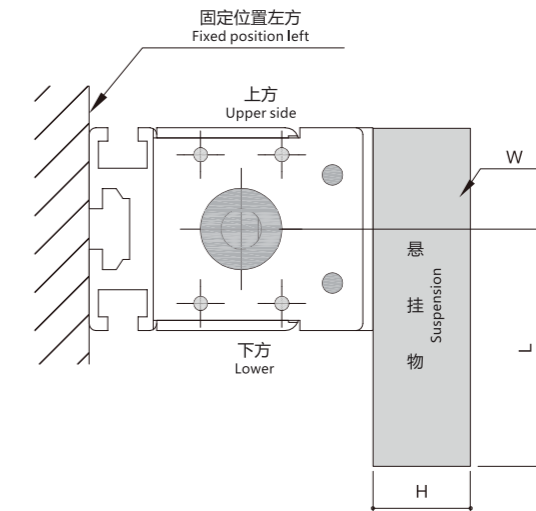

W	单头负载 Single head load
H	单头悬置物的宽度 Width of single head suspension
L	单头悬置物的长度 Length of single head suspension

位移时间和负载能力 Displacement Time And Load Capacity

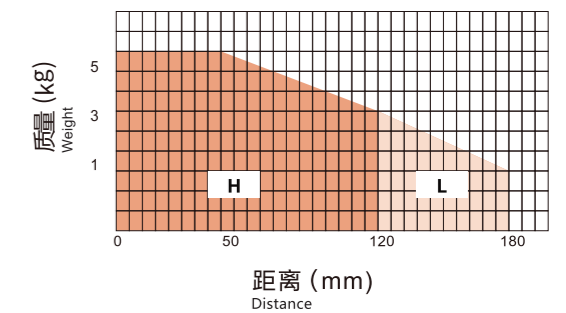
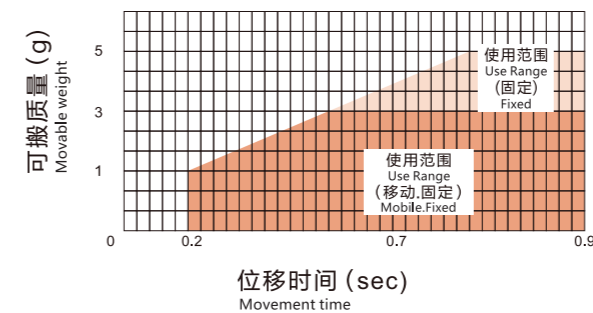

PT100

马达左折
Motor left fold

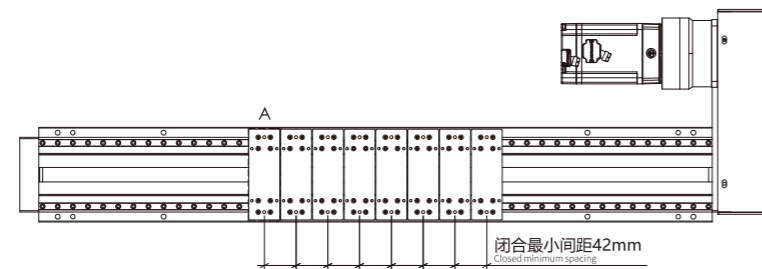
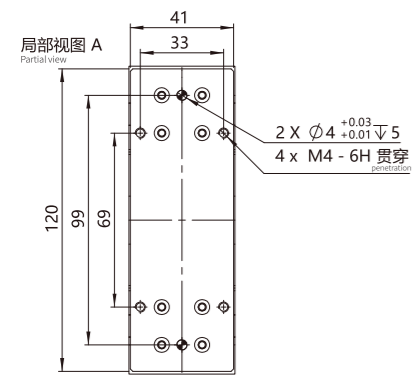
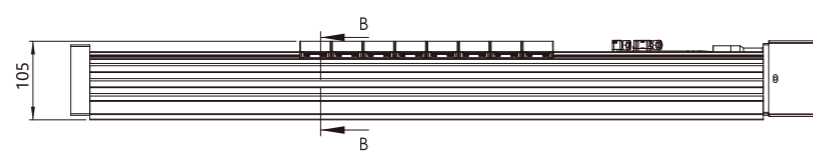
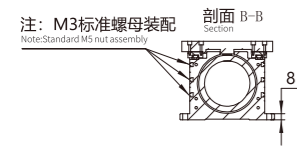
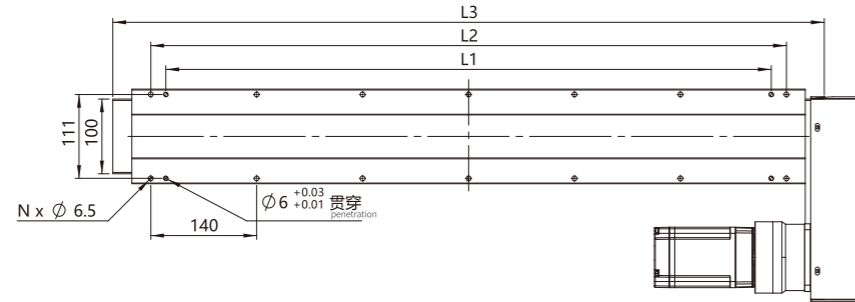

本体长度 (mm) Body Length	L1	L2	L3
940	800	840	940
1490	1350	1350	1400
2060	1900	1960	2060

意见反馈 Feedback

Feedback form area with horizontal dashed lines for text entry.

PT120 高精度/高速/安装简易
High Precision/High Speed/Easy Installation



本体宽度 Self Width 155mm 本体最长长度 Maximum Length Of Body 3140 mm 滑块最多个数 Maximum Number Of Sliders 36个 变距范围 Variable Pitch Range 60-180mm

型号表示方式 Ordering Method

PT120-H8-60-180-M-NL-ST60-L-MN5-001-□□

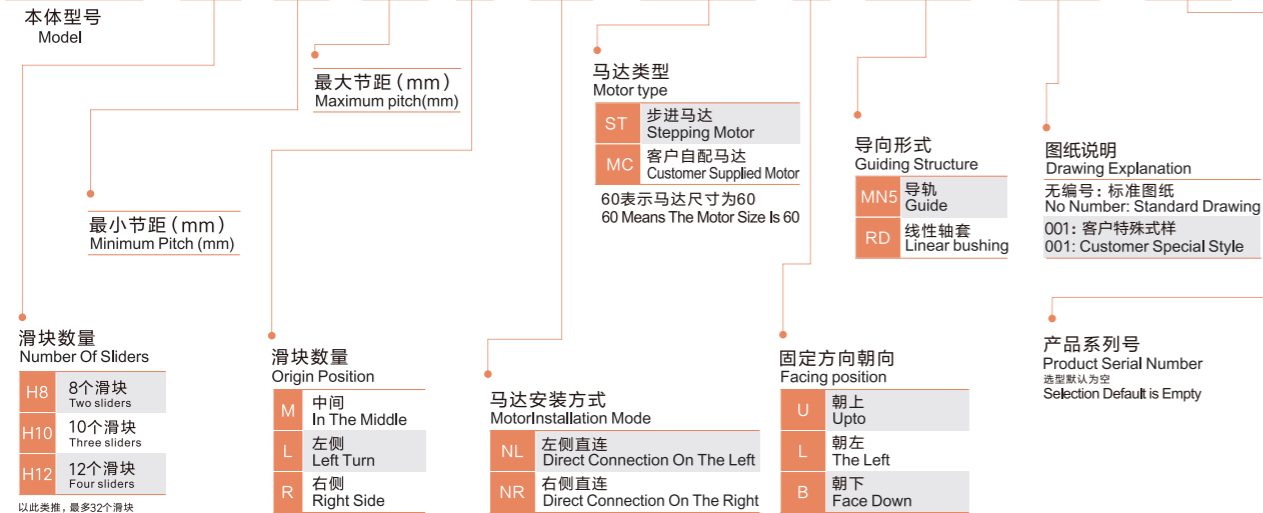

技术参数 Technical Parameter

规格 Spec	本体最长长度(mm) Maximum Length Of Body(mm)	1390			1750			2640			3140	
	滑块最多个数 Maximum Number Of Sliders	8	10	12	14	16	18	20	24	28	32	36
	变距范围(mm) Pitchrange	60~180	60~140	60~114	60~124	60~108	60~95	60~132	60~109	60~93	60~97	60~86
	重复定位精度(mm) Repeatability(mm)	±0.04			±0.08			±0.15			±0.25	
	定位精度(mm) Positioning Accuracy(mm)	±0.08			±0.15			±0.30			±0.50	
	滑块高度变化(mm) Slider Height Change	±0.2 (标准尺寸)										
	驱动方式 Drivemethod	外部输入(马达可选)										
	额定扭矩(N·m) Rated Torque(n·m)	0.5以上										
	最大使用频率 Maximum Frequency Of Use	100CPM										
	适用温度 Applicable Temperature	10-40℃										
部件 Parts	感应器外挂 Home Sensor Outside	可选										
	润滑 Lubricating	润滑脂										
	电机型号 Motor Model	750W+减速机 (马达可选)										

悬置物 Suspension

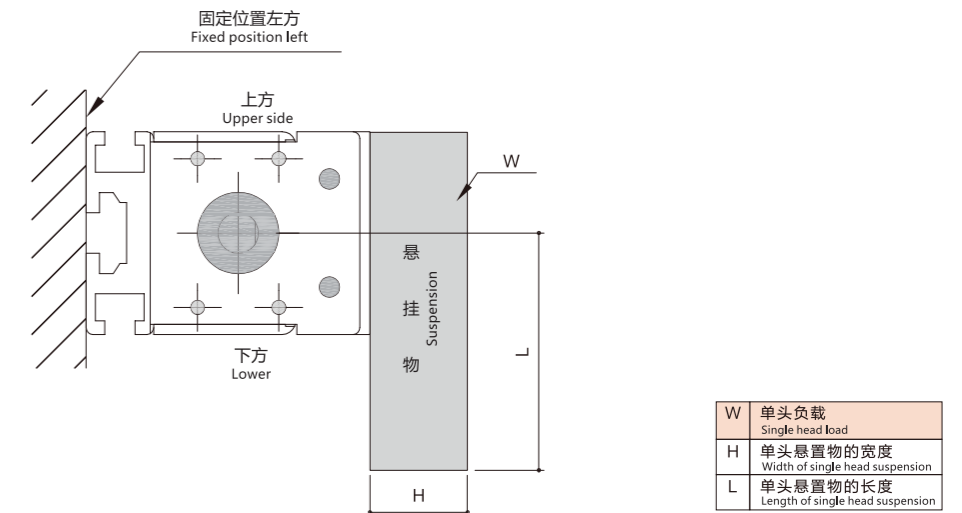

位移时间和负载能力 Displacement Time And Load Capacity

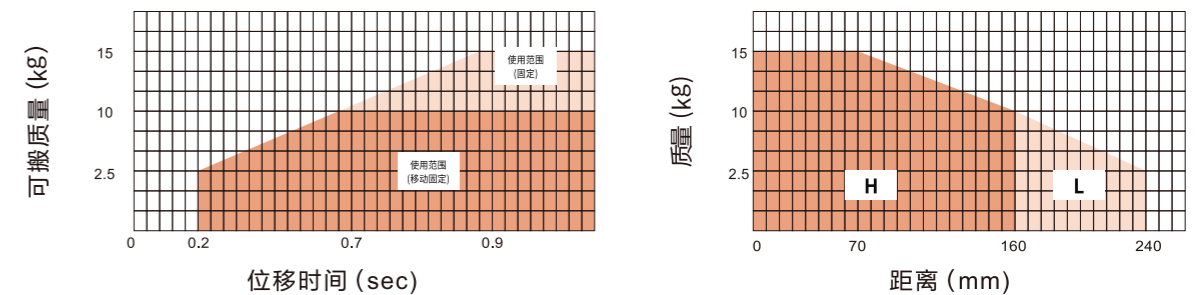

PT120

马达左折
Motor left fold

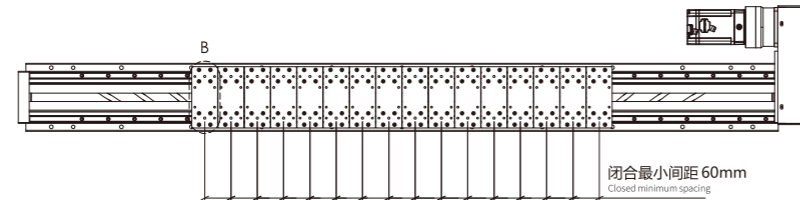
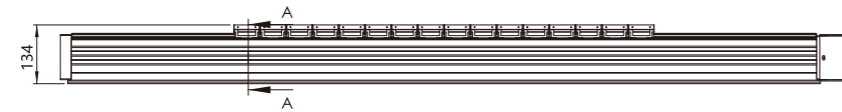
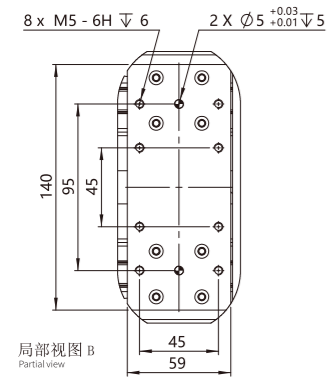
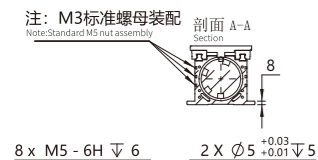
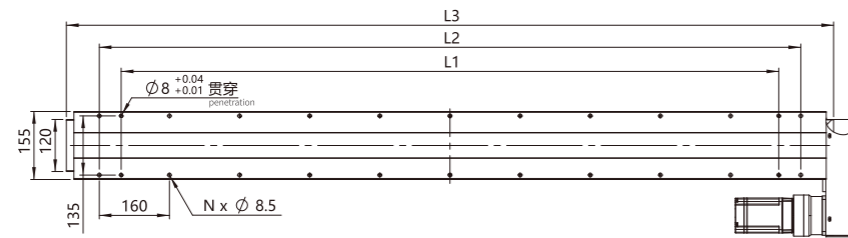

本体长度 (mm) Body Length	L1	L2	L3
1390	1200	1280	1390
1750	1500	1600	1750
2640	2500	2560	2640
3140	2800	2880	3140