

BSD0402G | Shaft dia.(轴径) 4 Lead(导程)2mm | C5&Ct7 |

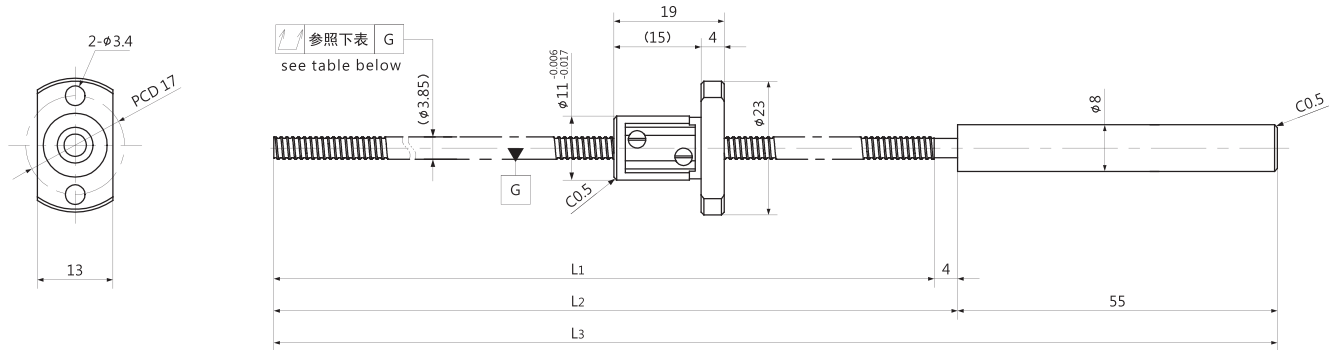

Unit (单位): mm

Ball Screw Specifications		主要技术参数
Ball size	钢珠直径	φ0.8
BCD	钢珠中心直径	4.15
Lead Angle	导程角	8°43′
Number of thread	螺纹条数	1
Thread direction	螺纹旋向	Right 右旋
Shaft root dia	丝杠轴底径	φ3.3
Number of circuit	循环数	2.7×1
Material 材质	Shaft 轴	S55C+SUS304
	Nut 螺母	SCM415H
Surface hardness 螺纹部表面硬度		HRC58~62 (Thread area)
Anti-rust treatment 防锈处理		Anti-rust oil 防锈油

Unit(单位): mm

Ball Screw Model 滚珠丝杠型号	Travel 行程	Grade 精度	Shaft length 丝杠轴长度			Lead accuracy 导程精度		Total Run-out 全跳动 ↗	Axial play 轴向间隙	Basic Load Rating 基本额定负载 N	
			L ₁	L ₂	L ₃	Travel deviation 代表移动量误差 e _p	Variation 波动 V ₃₀₀			Dynamic 额定动负载 Ca	Static 额定静负载 Coa
BSD0402G-96R155	75	C5	96	100	155	±0.018	0.018	0.050	~0.005	420	570
		Ct7				±0.050	0.052	0.075			
BSD0402G-216R275	195	C5	216	220	275	±0.023	0.018	0.065	~0.005	420	570
		Ct7				±0.037	0.052	0.100			

Note) Please designate end-journal profile with your sketch. 注) 轴端的追加加工请结合图纸进行指示。