

BSD0602 | Shaft dia.(轴径) 6 Lead(导程)2mm | C5&Ct7 |

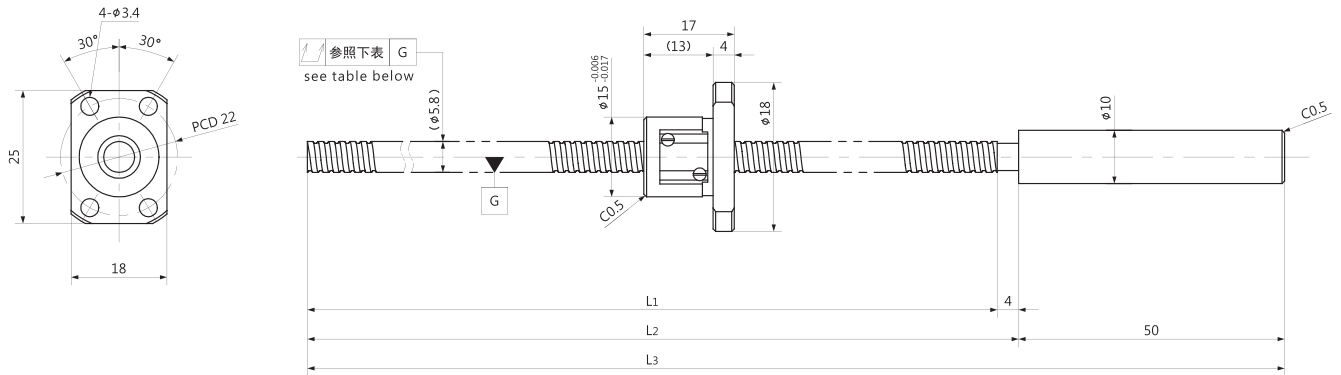

Unit (单位): mm

| Ball Screw Specifications | | 主要技术参数 |
|---------------------------|---------|---------------------------|
| Ball size 钢珠直径 | | φ1.0 |
| BCD 钢珠中心直径 | | 6.20 |
| Lead Angle 导程角 | | 5°52′ |
| Number of thread 螺纹条数 | | 1 |
| Thread direction 螺纹旋向 | | Right 右旋 |
| Shaft root dia 丝杠轴底径 | | φ5.1 |
| Number of circuit 循环数 | | 2.7×1 |
| Material 材质 | Shaft 轴 | S55C+SUS304 |
| | Nut 螺母 | SCM415H |
| Surface hardness 螺纹部表面硬度 | | HRC58~62 (Thread area) |
| Anti-rust treatment 防锈处理 | | Anti-rust oil 防锈油 |

Unit(单位): mm

| Ball Screw Model 滚珠丝杠型号 | Travel 行程 | Grade 精度 | Shaft length 丝杠轴长度 | | | Lead accuracy 导程精度 | | Total Run-out 全跳动 ↗ | Axial play 轴向间隙 | Basic Load Rating 基本额定负载 N | |
|----------------------------|--------------|-------------|-----------------------|----------------|----------------|-----------------------------------------------|-------------------------------------|---------------------------|--------------------|-------------------------------|------------------------|
| | | | L ₁ | L ₂ | L ₃ | Travel deviation 代表移动量误差 e _p | Variation 波动 V ₃₀₀ | | | Dynamic 额定动负载 Ca | Static 额定静负载 Coa |
| BSD0602-146R200 | 125 | C5 | 146 | 150 | 200 | ±0.020 | 0.018 | 0.050 | ~0.005 | 750 | 1200 |
| | | Ct7 | | | | ±0.025 | 0.052 | | | | |
| BSD0602-261R315 | 240 | C5 | 261 | 265 | 315 | ±0.023 | 0.018 | 0.065 | ~0.005 | 750 | 1200 |
| | | Ct7 | | | | ±0.045 | 0.052 | | | | |

Note) Please designate end-journal profile with your sketch. 注) 轴端的追加加工请结合图纸进行指示。