

# BSD0808D | Shaft dia.(轴径) 8 Lead(导程)8mm | C5&Ct7 |

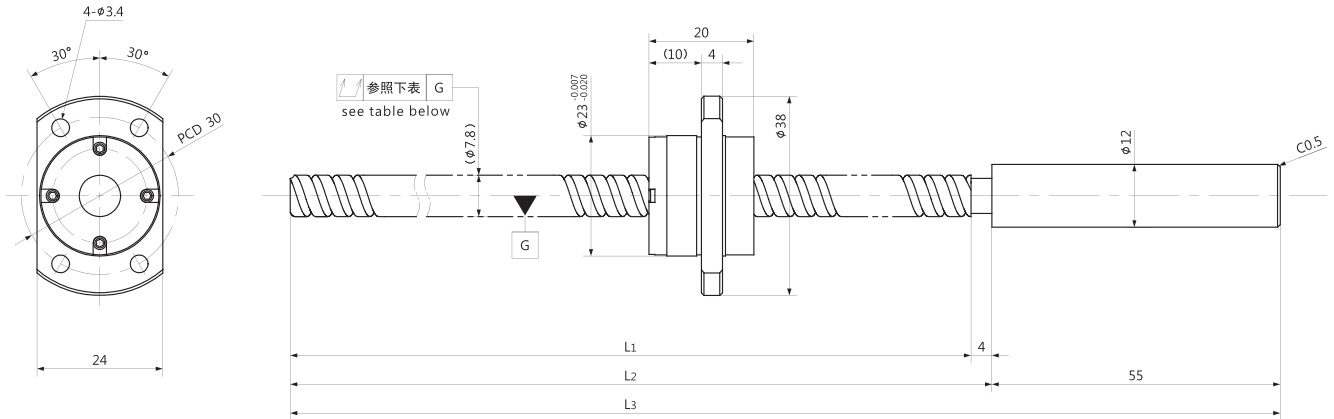

Unit (单位): mm

Ball Screw Specifications		主要技术参数
Ball size	钢珠直径	φ1.5875
BCD	钢珠中心直径	8.40
Lead Angle	导程角	16°52'
Number of thread	螺纹条数	2
Thread direction	螺纹旋向	Right 右旋
Shaft root dia	丝杠轴底径	φ6.7
Number of circuit	循环数	1.6×2
Material 材质	Shaft 轴	S55C+SUS304
	Nut 螺母	SCM415H
Surface hardness 螺纹部表面硬度		HRC58~62 (Thread area)
Anti-rust treatment 防锈处理		Anti-rust oil 防锈油

Unit(单位): mm

Ball Screw Model 滚珠丝杠型号	Travel 行程	Grade 精度	Shaft length 丝杠轴长度			Lead accuracy 导程精度		Total Run-out 全跳动 ↗	Axial play 轴向间隙	Basic Load Rating 基本额定负载 N	
			L1	L2	L3	Travel deviation 代表移动量误差 e <sub>p</sub>	Variation 波动 V <sub>300</sub>			Dynamic 额定动负载 Ca	Static 额定静负载 Coa
BSD0808D-196R255	170	C5	196	200	255	±0.020	0.018	0.065	~0.005	2200	3800
		Ct7				±0.034	0.052	0.100			
BSD0808D-356R415	330	C5	356	360	415	±0.025	0.018	0.075	~0.005	2200	3800
		Ct7				±0.062	0.052	0.100			

Note) Please designate end-journal profile with your sketch. 注) 轴端的追加加工请结合图纸进行指示。