

BSD1204G | Shaft dia.(轴径) 12 Lead(导程)4mm | C5&Ct7 |

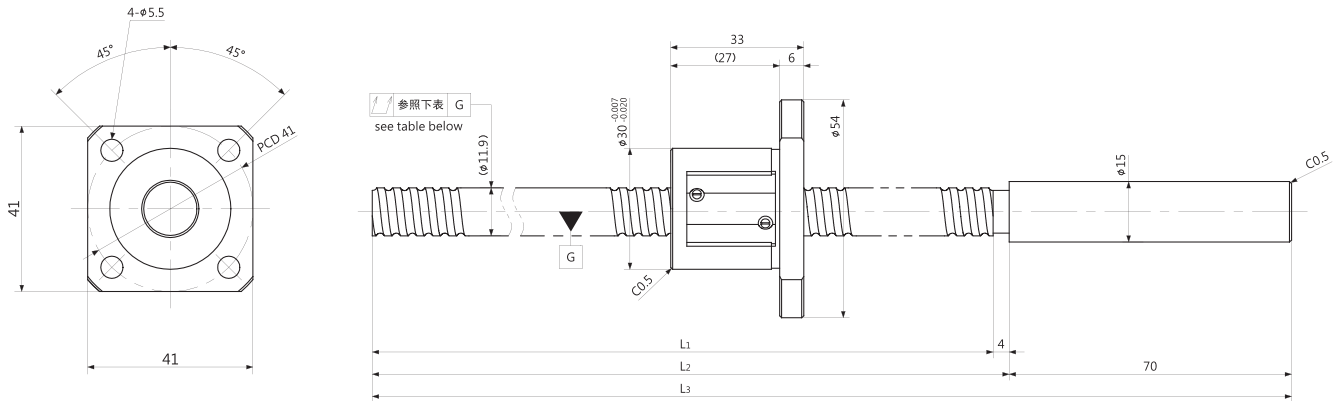

Unit (单位): mm

Ball Screw Specifications		主要技术参数
Ball size 钢珠直径		φ2.381
BCD 钢珠中心直径		12.30
Lead Angle 导程角		5°55′
Number of thread 螺纹条数		1
Thread direction 螺纹旋向		Right 右旋
Shaft root dia 丝杠轴底径		φ10.6
Number of circuit 循环数		3.7×1
Material 材质	Shaft 轴	S55C+SUS304
	Nut 螺母	SCM415H
Surface hardness 螺纹部表面硬度		HRC58~62 (Thread area)
Anti-rust treatment 防锈处理		Anti-rust oil 防锈油

Unit(单位): mm

Ball Screw Model 滚珠丝杠型号	Travel 行程	Grade 精度	Shaft length 丝杠轴长度			Lead accuracy 导程精度		Total Run-out 全跳动 ↗	Axial play 轴向间隙	Basic Load Rating 基本额定负载 N	
			L ₁	L ₂	L ₃	Travel deviation 代表移动量误差 e _p	Variation 波动 V ₃₀₀			Dynamic 额定动负载 Ca	Static 额定静负载 Coa
BSD1204G-196R270	160	C5	196	200	270	±0.020	0.018	0.055	~0.005	5700	11600
		Ct7				±0.034	0.052				
BSD1204G-356R410	320	C5	356	360	410	±0.025	0.018	0.080	~0.005	5700	11600
		Ct7				±0.062	0.052				
BSD1204G-800R874	760	C5	800	804	874	±0.035	0.018	0.090	~0.020	5700	11600
		Ct7				±0.139	0.052				

Note) Please designate end-journal profile with your sketch. 注) 轴端的追加加工请结合图纸进行指示。