

FXM0602 | Shaft dia.(轴径) 6 Lead(导程)2mm | C3&C5 |

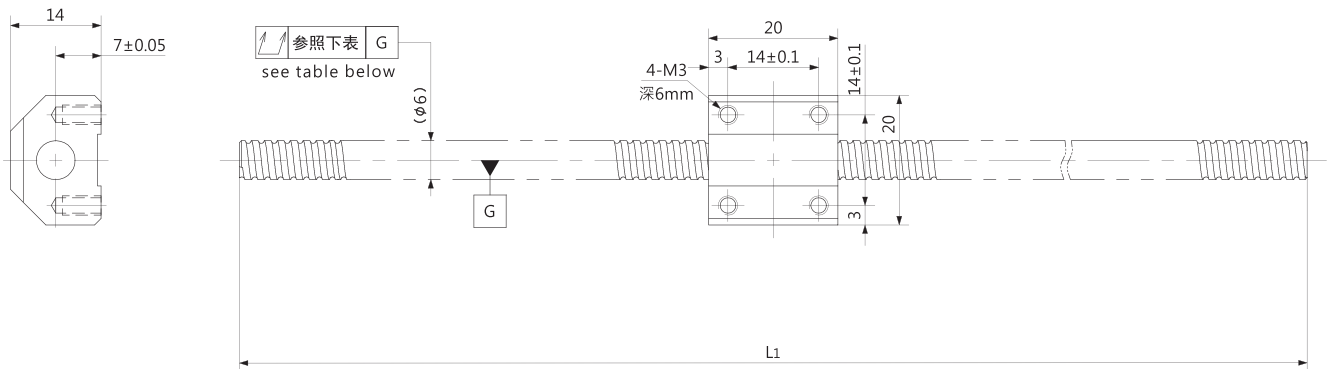

Unit (单位): mm

Ball Screw Specifications		主要技术参数
Ball size 钢珠直径		φ1.0
BCD 钢珠中心直径		6.20
Lead Angle 导程角		5°52′
Number of thread 螺纹条数		1
Thread direction 螺纹旋向		Right 右旋
Shaft root dia 丝杠轴底径		φ5.1
Number of circuit 循环数		2.7×1
Material 材质	Shaft 轴	S55C
	Nut 螺母	SCM415H
Surface hardness 螺纹部表面硬度		HRC58~62 (Thread area)
Anti-rust treatment 防锈处理		Anti-rust oil 防锈油

Unit(单位): mm

Ball Screw Model 滚珠丝杠型号	Travel 行程	Grade 精度	Shaft length 丝杠轴长度	Lead accuracy 导程精度		Total Run-out 全跳动	Axial play 轴向间隙	Preload Torque 预压扭矩 Nm	Basic Load Rating 基本额定负载 N	
			L ₁	Travel deviation 代表移动量误差 e _p	Variation 波动 V ₃₀₀				Dynamic 额定动负载 Ca	Static 额定静负载 Coa
FXM0602-064R108	88	C3	108	±0.008	0.008	0.050	0 Spacer ball 间隔钢珠 (1:1)	0.003~0.007	470	590
FXM0602-094R138	118		138	±0.008						
FXM0602-124R168	148		168	±0.010						
FXM0602-064R108	88	C5	108	±0.018	0.018	0.090	~0.005	-	750	1200
FXM0602-094R138	118		138	±0.018						
FXM0602-124R168	148		168	±0.020						

Note) Please designate end-journal profile with your sketch. (注) 轴端的追加加工请结合图纸进行指示。