

FXM0801 | Shaft dia.(轴径) 8 Lead(导程)1mm | C3&C5 |

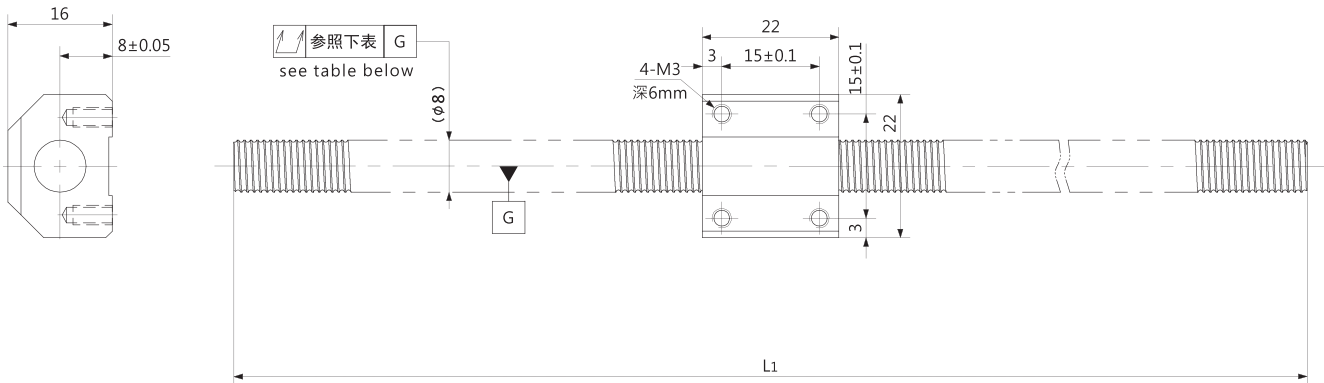

Unit (单位): mm

Ball Screw Specifications		主要技术参数
Ball size 钢珠直径		φ0.8
BCD 钢珠中心直径		8.15
Lead Angle 导程角		2°15′
Number of thread 螺纹条数		1
Thread direction 螺纹旋向		Right 右旋
Shaft root dia 丝杠轴底径		φ7.3
Number of circuit 循环数		3.7×1
Material 材质	Shaft 轴	S55C
	Nut 螺母	SCM415H
Surface hardness 螺纹部表面硬度		HRC58~62 (Thread area)
Anti-rust treatment 防锈处理		Anti-rust oil 防锈油

Unit(单位):mm

Ball Screw Model 滚珠丝杠型号	Travel 行程	Grade 精度	Shaft length 丝杠轴长度	Lead accuracy 导程精度		Total Run-out 全跳动 ↗	Axial play 轴向间隙 Spacer ball 间隔钢珠 (1:1)	Preload Torque 预压扭矩 Nm	Basic Load Rating 基本额定负载 N	
			L ₁	Travel deviation 代表移动量误差 e _p	Variation 波动 V ₃₀₀				Dynamic 额定动负载 Ca	Static 额定静负载 Coa
FXM0801-065R115	95	C3	115	±0.008	0.008	0.060	0.004~0.020	490	820	
FXM0801-095R145	125		145	±0.008						
FXM0801-125R175	155		175	±0.010						
FXM0801-175R225	205		225	±0.010						
FXM0801-065R115	95	C5	115	±0.018	0.018	0.090	~0.005	-	780	1650
FXM0801-095R145	125		145	±0.018						
FXM0801-125R175	155		175	±0.020						
FXM0801-175R225	205		225	±0.020						

(Note) Please designate end-journal profile with your sketch. 注) 轴端的追加加工请结合图纸进行指示。