

GG1404 | Shaft dia.(轴径) 14 | Lead(导程)4mm | C3&C5

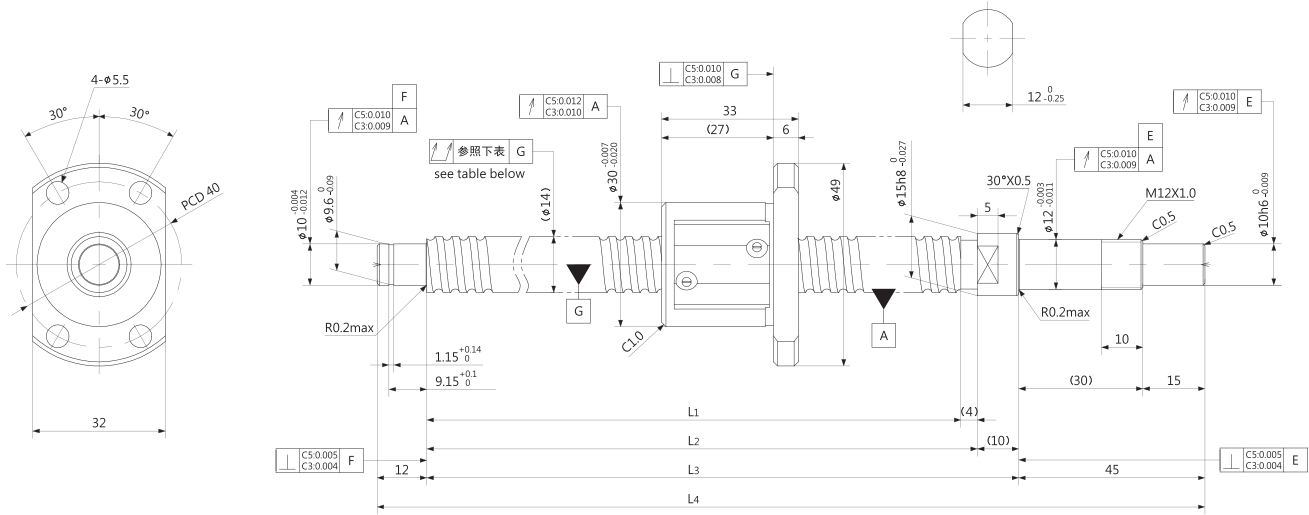

Unit (单位): mm

Ball Screw Specifications		主要技术参数	
Ball size 钢珠直径	φ2.381	BCD 钢珠中心直径	14.30
Lead Angle 导程角	5°05′	Number of thread 螺纹条数	1
Thread direction 螺纹旋向	Right 右旋	Shaft root dia 丝杠轴底径	φ11.8
Number of circuit 循环数	3.7×1	Material 材质	Shaft 轴 S55C
			Nut 螺母 SCM415H
Surface hardness 螺纹部表面硬度	HRC58~62 (Thread area)	Anti-rust treatment 防锈处理	Anti-rust oil 防锈油

Unit(单位):mm

Ball Screw Model 滚珠丝杠型号	Travel 行程	Grade 精度	Shaft length 丝杠轴长度				Lead accuracy 导程精度		Total Run-out 全跳动	Axial play 轴向间隙	Preload Torque 预压扭矩 Nm	Basic Load Rating 基本额定负载 N	
			L1	L2	L3	L4	Travel deviation 代表移动量误差 e _p	Variation 波动 V ₃₀₀				Dynamic 额定动负载 Ca	Static 额定静负载 Coa
GG1404-148R219	100	C3	148	152	162	219	±0.010	0.008	0.030	0 Spacer ball 间隔钢珠 (1:1)	0.020~0.070	3600	5800
GG1404-198R269	150		198	202	212	269	±0.010		0.030				
GG1404-248R319	200		248	252	262	319	±0.012		0.040				
GG1404-348R419	300		348	352	362	419	±0.013		0.050				
GG1404-448R519	400		448	452	462	519	±0.015		0.055				
GG1404-148R219	100	C5	148	152	162	219	±0.020	0.018	0.045	~0.005	-	5700	11600
GG1404-198R269	150		198	202	212	269	±0.020		0.045				
GG1404-248R319	200		248	252	262	319	±0.023		0.055				
GG1404-348R419	300		348	352	362	419	±0.025		0.060				
GG1404-448R519	400		448	452	462	519	±0.027		0.075				

Note) Please designate end-journal profile with your sketch. 注) 轴端的追加加工请结合图纸进行指示。