

GLM0401

Shaft dia.(轴径) 4

Lead(导程)1mm

C3&C5

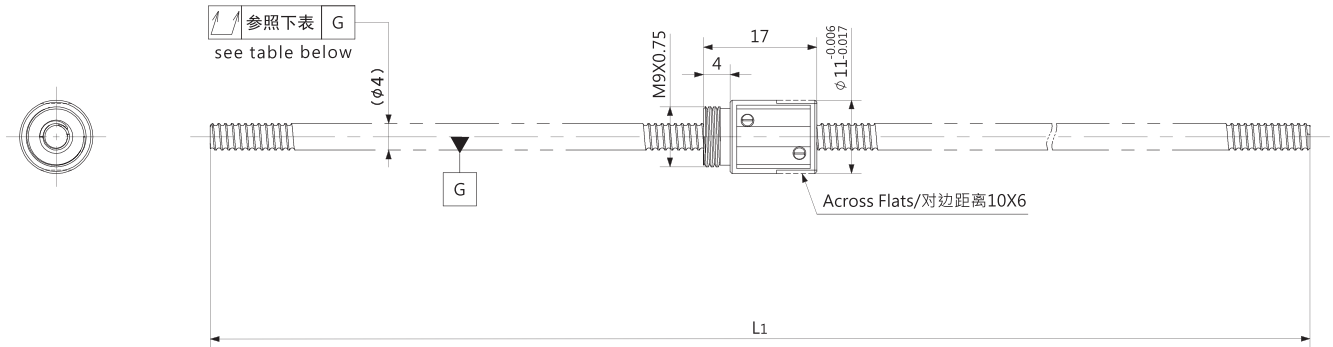

Unit (单位): mm

Ball Screw Specifications		主要技术参数
Ball size 钢珠直径		φ0.8
BCD 钢珠中心直径		4.15
Lead Angle 导程角		4°23'
Number of thread 螺纹条数		1
Thread direction 螺纹旋向		Right 右旋
Shaft root dia 丝杠轴底径		φ3.3
Number of circuit 循环数		3.7×1
Material 材质	Shaft 轴	S55C
	Nut 螺母	SCM415H
Surface hardness 螺纹部表面硬度		HRC58~62 (Thread area)
Anti-rust treatment 防锈处理		Anti-rust oil 防锈油

Unit(单位): mm

Ball Screw Model 滚珠丝杠型号	Travel 行程	Grade 精度	Shaft length 丝杠轴长度	Lead accuracy 导程精度		Total Run-out 全跳动	Axial play 轴向间隙	Preload Torque 预压扭矩 Nm	Basic Load Rating 基本额定负载 N	
			L ₁	Travel deviation 代表移动量误差 e _p	Variation 波动 V ₃₀₀				Dynamic 额定动负载 Ca	Static 额定静负载 Coa
GLM0401-044R084	64	C3	84	±0.008	0.008	0.035	0 Spacer ball 间隔钢珠 (1:1)	~0.004	350	400
GLM0401-064R104	84		104	±0.008						
GLM0401-094R134	114		134	±0.008						
GLM0401-044R084	64	C5	84	±0.018	0.018	0.090	~0.005	-	560	790
GLM0401-064R104	84		104	±0.018						
GLM0401-094R134	114		134	±0.018						

Note) Please designate end-journal profile with your sketch. (注) 轴端的追加加工请结合图纸进行指示。