

# GLM0801.5 | Shaft dia.(轴径) 8 Lead(导程)1.5mm | C3&C5 |

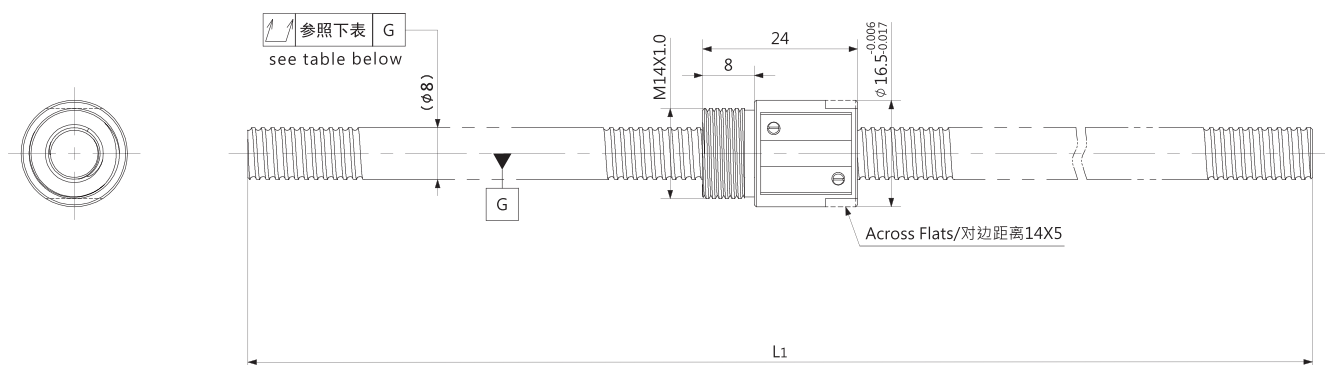

Unit (单位): mm

Ball Screw Specifications		主要技术参数
Ball size 钢珠直径		φ1
BCD 钢珠中心直径		8.20
Lead Angle 导程角		3°20′
Number of thread 螺纹条数		1
Thread direction 螺纹旋向		Right 右旋
Shaft root dia 丝杠轴底径		φ7.1
Number of circuit 循环数		3.7×1
Material 材质	Shaft 轴	S55C
	Nut 螺母	SCM415H
Surface hardness 螺纹部表面硬度		HRC58~62 (Thread area)
Anti-rust treatment 防锈处理		Anti-rust oil 防锈油

Unit(单位): mm

Ball Screw Model 滚珠丝杠型号	Travel 行程	Grade 精度	Shaft length 丝杠轴长度 L <sub>1</sub>	Lead accuracy 导程精度		Total Run-out 全跳动 ↗	Axial play 轴向间隙 0 Spacer ball 间隔钢珠 (1:1)	Preload Torque 预压扭矩 Nm	Basic Load Rating 基本额定负载 N	
				Travel deviation 代表移动量误差 e <sub>p</sub>	Variation 波动 V <sub>300</sub>				Dynamic 额定动负载 Ca	Static 额定静负载 Coa
GLM0801.5-330R330C3	305	C3	330	±0.013	0.008	0.060	0.002~0.008	700	1100	
GLM0801.5-600R600C5	575	C5	600	±0.030	0.018	0.090	~0.005	-	1100	2200

Note) Please designate end-journal profile with your sketch. 注) 轴端的追加加工请结合图纸进行指示。