

GLM0805

Shaft dia.(轴径) 8

Lead(导程)5mm

C3&C5

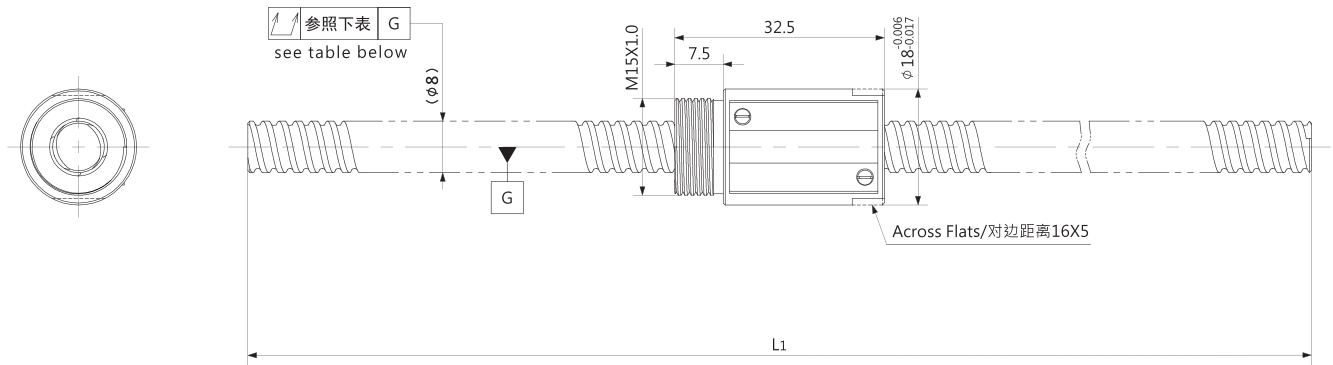

Unit (单位): mm

Ball Screw Specifications		主要技术参数
Ball size 钢珠直径		φ1.5875
BCD 钢珠中心直径		8.30
Lead Angle 导程角		10°51′
Number of thread 螺纹条数		2
Thread direction 螺纹旋向		Right 右旋
Shaft root dia 丝杠轴底径		φ6.6
Number of circuit 循环数		2.7×1
Material 材质	Shaft 轴	S55C
	Nut 螺母	SCM415H
Surface hardness 螺纹部表面硬度		HRC58~62 (Thread area)
Anti-rust treatment 防锈处理		Anti-rust oil 防锈油

Unit(单位):mm

Ball Screw Model 滚珠丝杠型号	Travel 行程	Grade 精度	Shaft length 丝杠轴长度	Lead accuracy 导程精度		Total Run-out 全跳动 ↗	Axial play 轴向间隙 0 Spacer ball 间隔钢珠 (1:1)	Preload Torque 预压扭矩 Nm	Basic Load Rating 基本额定负载 N	
			L ₁	Travel deviation 代表移动量误差 e _p	Variation 波动 V ₃₀₀				Dynamic 额定动负载 Ca	Static 额定静负载 Coa
GLM0805-154R204	173	C3	204	±0.010	0.008	0.060	~0.015	1150	1500	
GLM0805-204R254	223		254	±0.012						
GLM0805-254R304	273		304	±0.012						
GLM0805-304R354	323		354	±0.012						
GLM0805-354R404	373		404	±0.013						
GLM0805-154R204	173	C5	204	±0.020	0.018	0.090	~0.005	-	1850	3000
GLM0805-204R254	223		254	±0.023						
GLM0805-254R304	273		304	±0.023						
GLM0805-304R354	323		354	±0.023						
GLM0805-354R404	373		404	±0.025						

Note) Please designate end-journal profile with your sketch. 注) 轴端的追加加工请结合图纸进行指示。