

GLM1202 | Shaft dia.(轴径) 12 | Lead(导程)2mm | C3&C5 |

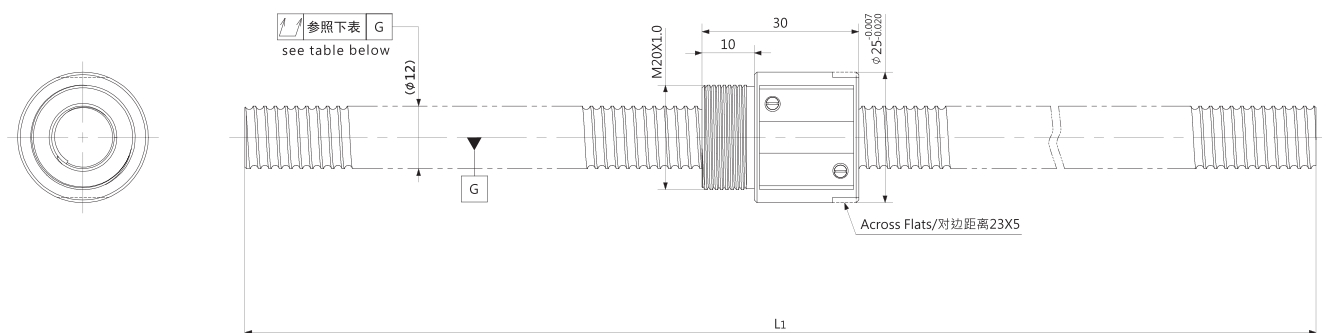

Unit (单位): mm

Ball Screw Specifications		主要技术参数
Ball size 钢球直径		φ1.5875
BCD 钢球中心直径		12.30
Lead Angle 导程角		2°58′
Number of thread 螺纹条数		1
Thread direction 螺纹旋向		Right 右旋
Shaft root dia 丝杠轴底径		φ10.6
Number of circuit 循环数		3.7×1
Material 材质	Shaft 轴	S55C
	Nut 螺母	SCM415H
Surface hardness 螺纹部表面硬度		HRC58~62 (Thread area)
Anti-rust treatment 防锈处理		Anti-rust oil 防锈油

Unit(单位):mm

Ball Screw Model 滚珠丝杠型号	Travel 行程	Grade 精度	Shaft length 丝杠轴长度	Lead accuracy 导程精度		Total Run-out 全跳动	Axial play 轴向间隙	Preload Torque 预压扭矩 Nm	Basic Load Rating 基本额定负载 N	
			L ₁	Travel deviation 代表移动量误差 e _p	Variation 波动 V ₃₀₀				Dynamic 额定动负载 Ca	Static 额定静负载 Coa
GLM1202-085R154	127	C3	154	±0.008	0.008	0.070	0 Spacer ball 间隔钢珠 (1:1)	0.008~0.040	1900	3200
GLM1202-135R204	177		204	±0.010						
GLM1202-185R254	227		254	±0.010						
GLM1202-235R304	277		304	±0.012						
GLM1202-285R354	327		354	±0.012						
GLM1202-085R154	127	C5	154	±0.018	0.018	0.090	~0.005	-	3000	6400
GLM1202-135R204	177		204	±0.020						
GLM1202-185R254	227		254	±0.020						
GLM1202-235R304	277		304	±0.023						
GLM1202-285R354	327		354	±0.023						

Note) Please designate end-journal profile with your sketch. 注) 轴端的追加加工请结合图纸进行指示。