

GLM1404 | Shaft dia.(轴径) 14 | Lead(导程)4mm | C3&C5 |

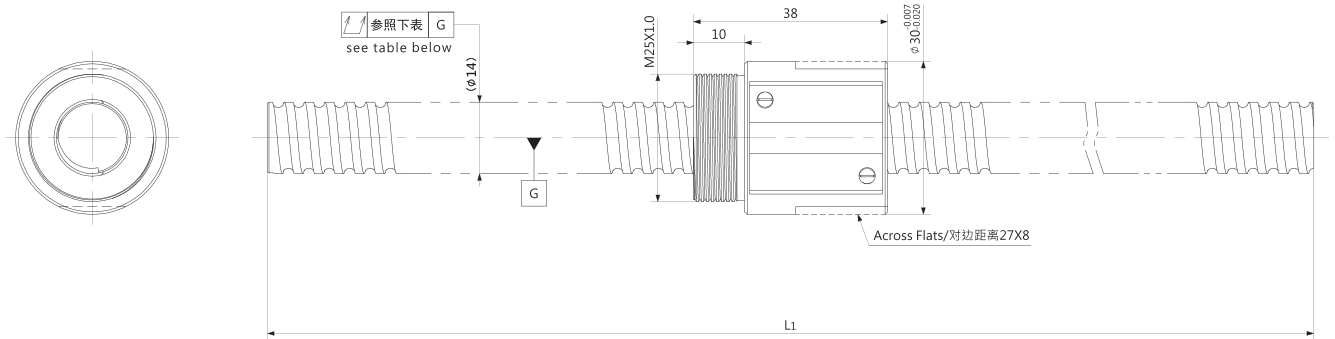

Unit (单位): mm

| Ball Screw Specifications | | 主要技术参数 |
|---------------------------|---------|---------------------------|
| Ball size 钢珠直径 | | $\phi 2.381$ |
| BCD 钢珠中心直径 | | 14.30 |
| Lead Angle 导程角 | | $5^{\circ}05'$ |
| Number of thread 螺纹条数 | | 2 |
| Thread direction 螺纹旋向 | | Right 右旋 |
| Shaft root dia 丝杠轴底径 | | $\phi 11.8$ |
| Number of circuit 循环数 | | 3.7×1 |
| Material 材质 | Shaft 轴 | S55C |
| | Nut 螺母 | SCM415H |
| Surface hardness 螺纹部表面硬度 | | HRC58~62 (Thread area) |
| Anti-rust treatment 防锈处理 | | Anti-rust oil 防锈油 |

Unit(单位): mm

| Ball Screw Model 滚珠丝杠型号 | Travel 行程 | Grade 精度 | Shaft length 丝杠轴长度 | Lead accuracy 导程精度 | | Total Run-out 全跳动 | Axial play 轴向间隙 | Preload Torque 预压扭矩 Nm | Basic Load Rating 基本额定负载 N | |
|----------------------------|--------------|-------------|-----------------------|---|-------------------------------------|----------------------|-----------------------------------|------------------------------|-------------------------------|------------------------|
| | | | L ₁ | Travel deviation 代表移动量误差 e _p | Variation 波动 V ₃₀₀ | | | | Dynamic 额定动负载 Ca | Static 额定静负载 Coa |
| GLM1404-148R219 | 183 | C3 | 219 | ± 0.010 | 0.008 | 0.070 | 0 Spacer ball 间隔钢珠 (1:1) | 0.020~0.070 | 3600 | 5800 |
| GLM1404-198R269 | 233 | | 269 | ± 0.010 | | | | | | |
| GLM1404-248R319 | 283 | | 319 | ± 0.012 | | | | | | |
| GLM1404-348R419 | 383 | | 419 | ± 0.013 | | | | | | |
| GLM1404-448R519 | 483 | | 519 | ± 0.015 | | | | | | |
| GLM1404-148R219 | 183 | C5 | 219 | ± 0.020 | 0.018 | 0.015 | ~0.005 | - | 5700 | 11600 |
| GLM1404-198R269 | 233 | | 269 | ± 0.020 | | | | | | |
| GLM1404-248R319 | 283 | | 319 | ± 0.023 | | | | | | |
| GLM1404-348R419 | 383 | | 419 | ± 0.025 | | | | | | |
| GLM1404-448R519 | 483 | | 519 | ± 0.027 | | | | | | |

Note) Please designate end-journal profile with your sketch. 注) 轴端的追加加工请结合图纸进行指示。