

# GLR0805 | Shaft dia.(轴径) 8 Lead(导程)5mm | C5&Ct7C10 |

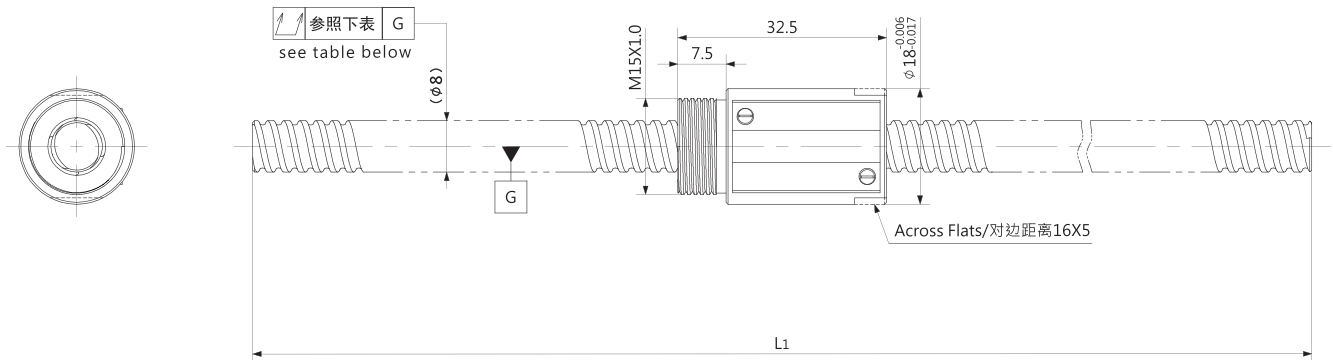

Unit (单位): mm

Ball Screw Specifications		主要技术参数
Ball size 钢珠直径		φ1.5875
BCD 钢珠中心直径		8.30
Lead Angle 导程角		10°51′
Number of thread 螺纹条数		2
Thread direction 螺纹旋向		Right 右旋
Shaft root dia 丝杠轴底径		φ6.6
Number of circuit 循环数		2.7×1
Material 材质	Shaft 轴	S55C
	Nut 螺母	SCM415H
Surface hardness 螺纹部表面硬度		HRC58~62 (Thread area)
Anti-rust treatment 防锈处理		Anti-rust oil 防锈油

Unit(单位): mm

Ball Screw Model 滚珠丝杠型号	Travel 行程	Grade 精度	Shaft length 丝杠轴长度	Lead accuracy 导程精度		Total Run-out 全跳动	Axial play 轴向间隙	Basic Load Rating 基本额定负载 N	
			L <sub>1</sub>	Travel deviation 代表移动量误差 e <sub>p</sub>	Variation 波动 V <sub>300</sub>			Dynamic 额定动负载 Ca	Static 额定静负载 Coa
GLR0805-1200R1200C5	1170	C5	1200	±0.046	0.018	0.150	~0.005	1850	3000
GLR0805-1200R1200C7		Ct7		±0.208	0.052	0.320	~0.020		
GLR0805-1200R1200C10		Ct10		±0.840	0.210	0.640	~0.050		

Note) Please designate end-journal profile with your sketch. (注) 轴端的追加加工请结合图纸进行指示。