

GLR1202 | Shaft dia.(轴径) 12 Lead(导程)2mm | C5&Ct7C10 |

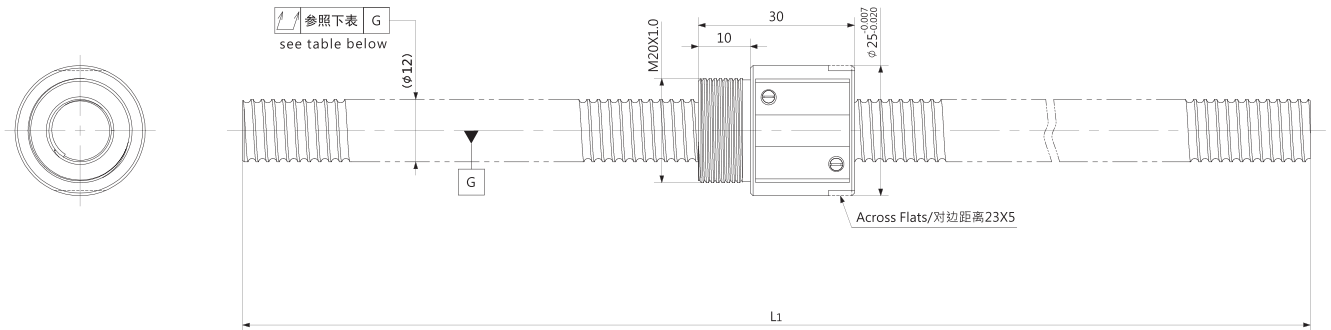

Unit(单位): mm

Ball Screw Specifications		主要技术参数
Ball size	钢珠直径	$\phi 1.5875$
BCD	钢珠中心直径	12.30
Lead Angle	导程角	$2^{\circ}58'$
Number of thread	螺纹条数	1
Thread direction	螺纹旋向	Right 右旋
Shaft root dia	丝杠轴底径	$\phi 10.6$
Number of circuit	循环数	3.7×1
Material 材质	Shaft 轴	S55C
	Nut 螺母	SCM415H
Surface hardness 螺纹部表面硬度		HRC58~62 (Thread area)
Anti-rust treatment 防锈处理		Anti-rust oil 防锈油

Unit(单位): mm

Ball Screw Model 滚珠丝杠型号	Travel 行程	Grade 精度	Shaft length 丝杠轴长度 L_1	Lead accuracy 导程精度		Total Run-out 全跳动 \uparrow	Axial play 轴向间隙	Basic Load Rating 基本额定负载 N	
				Travel deviation 代表移动量误差 e_p	Variation 波动 V_{300}			Dynamic 额定动负载 C_a	Static 额定静负载 C_{0a}
GLR1202-1200R1200C5	1170	C5	1200	± 0.046	0.018	0.150	~ 0.005	3000	6400
GLR1202-1200R1200C7		Ct7		± 0.208	0.052	0.320	~ 0.020		
GLR1202-1200R1200C10		Ct10		± 0.840	0.210	0.640	~ 0.050		

Note) Please designate end-journal profile with your sketch. 注) 轴端的追加加工请结合图纸进行指示。