

# GLR1404 | Shaft dia.(轴径) 14 Lead(导程)4mm | C5&Ct7C10 |

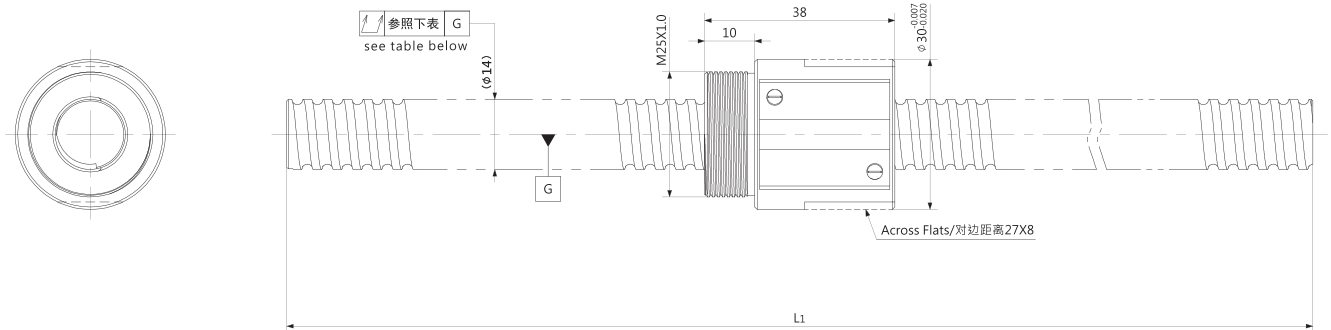

Unit (单位): mm

Ball Screw Specifications		主要技术参数
Ball size	钢珠直径	$\phi 2.381$
BCD	钢珠中心直径	12.30
Lead Angle	导程角	$5^{\circ}05'$
Number of thread	螺纹条数	2
Thread direction	螺纹旋向	Right 右旋
Shaft root dia	丝杠轴底径	$\phi 11.8$
Number of circuit	循环数	$3.7 \times 1$
Material 材质	Shaft 轴	S55C
	Nut 螺母	SCM415H
Surface hardness 螺纹部表面硬度		HRC58~62 (Thread area)
Anti-rust treatment 防锈处理		Anti-rust oil 防锈油

Unit(单位): mm

Ball Screw Model 滚珠丝杠型号	Travel 行程	Grade 精度	Shaft length 丝杠轴长度	Lead accuracy 导程精度		Total Run-out 全跳动 $\uparrow\uparrow$	Axial play 轴向间隙	Basic Load Rating 基本额定负载 N	
			$L_1$	Travel deviation 代表移动量误差 $e_p$	Variation 波动 $V_{300}$			Dynamic 额定动负载 $C_a$	Static 额定静负载 $C_{0a}$
GLR1404-1200R1200C5	1165	C5	1200	$\pm 0.046$	0.018	0.150	$\sim 0.005$	5700	11600
GLR1404-1200R1200C7		Ct7		$\pm 0.208$	0.052	0.320	$\sim 0.020$		
GLR1404-1200R1200C10		Ct10		$\pm 0.840$	0.210	0.640	$\sim 0.050$		

Note) Please designate end-journal profile with your sketch. 注) 轴端的追加加工请结合图纸进行指示。