

# GSR1003 | Shaft dia.(轴径) 10 Lead(导程)3mm | C5&Ct7&Ct10 |

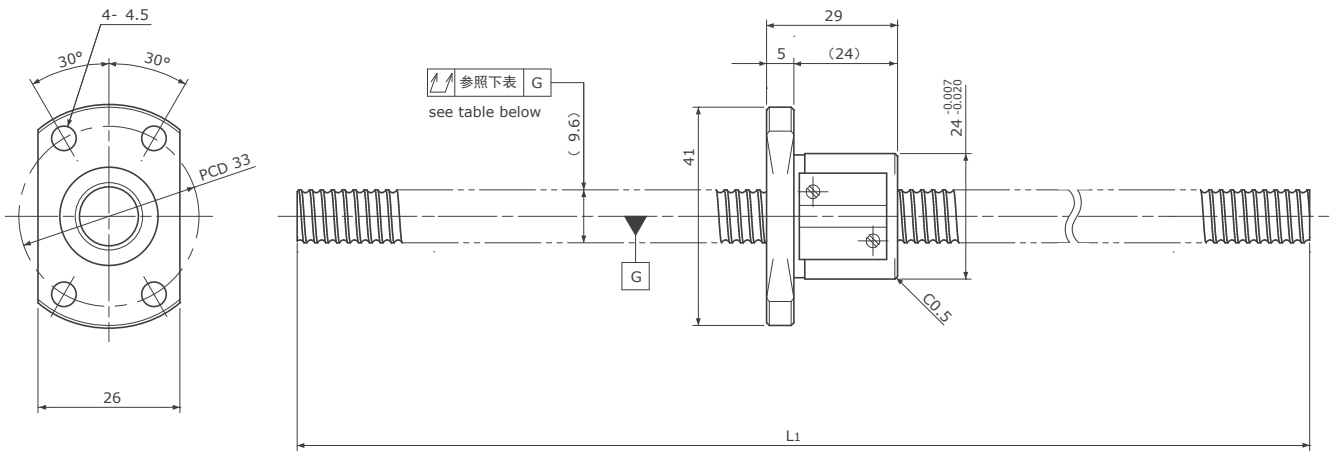

Unit (单位): mm

Ball Screw Specifications		主要技术参数
Ball size	钢珠直径	φ2.0
BCD	钢珠中心直径	10.30
Lead Angle	导程角	5°18′
Number of thread	螺纹条数	1
Thread direction	螺纹旋向	Right 右旋
Shaft root dia	丝杠轴底径	φ8.2
Number of circuit	循环数	3.7×1
Material 材质	Shaft 轴	S55C
	Nut 螺母	SCM415H
Surface hardness	螺纹部表面硬度	HRC58~62 (Thread area)
Anti-rust treatment	防锈处理	Anti-rust oil 防锈油

Unit(单位): mm

Ball Screw Model 滚珠丝杠型号	Travel 行程	Grade 精度	Shaft length 丝杠轴长度	Lead accuracy 导程精度		Total Run-out 全跳动	Axial play 轴向间隙	Preload Torque 预压扭矩 Nm	Basic Load Rating 基本额定负载 N	
			L <sub>1</sub>	Travel deviation 代表移动量误差 e <sub>p</sub>	Variation 波动 V <sub>300</sub>				Dynamic 额定动负载 Ca	Static 额定静负载 Coa
GSR1003-600R600C5	570	C5	600	±0.030	0.018	0.090	~0.005	-	3900	7200
GSR1003-600R600C7	570	Ct7	600	±0.104	0.050	0.150	~0.020			
GSR1003-600R600C10	570	Ct10	600	±0.420	0.210	0.350	~0.050			

(Note) Please designate end-journal profile with your sketch. 注) 轴端的追加加工请结合图纸进行指示。