

GSR1020 | Shaft dia.(轴径) 10 Lead(导程)20mm | C5&Ct7&Ct10 |

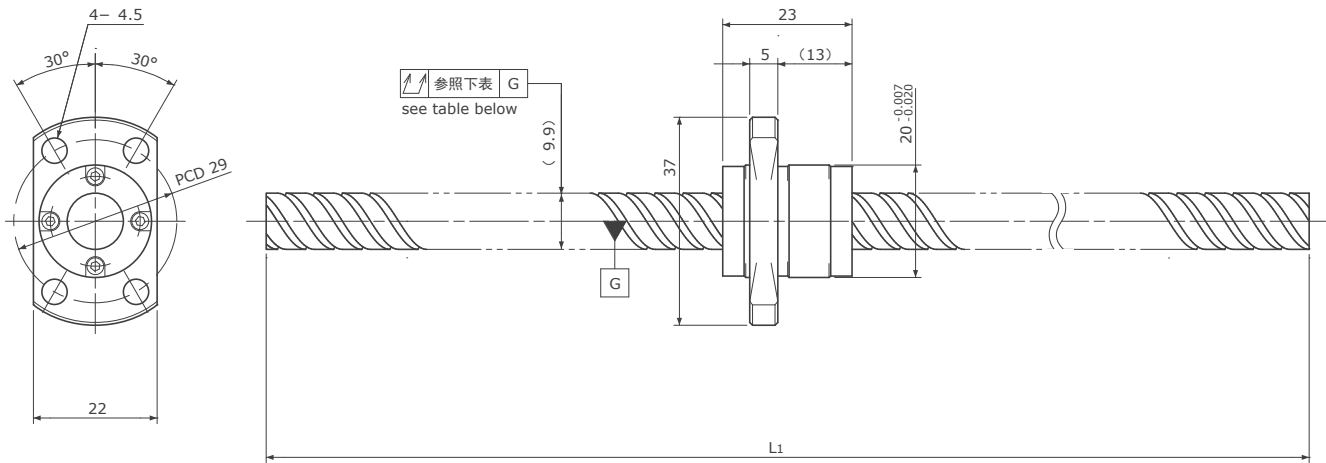

Unit (单位): mm

Ball Screw Specifications		主要技术参数
Ball size 钢珠直径		φ1.5875
BCD 钢珠中心直径		10.40
Lead Angle 导程角		31°28′
Number of thread 螺纹条数		4
Thread direction 螺纹旋向		Right 右旋
Shaft root dia 丝杠轴底径		φ8.7
Number of circuit 循环数		0.7×4
Material 材质	Shaft 轴	S55C
	Nut 螺母	SCM415H
Surface hardness 螺纹部表面硬度		HRC58~62 (Thread area)
Anti-rust treatment 防锈处理		Anti-rust oil 防锈油

Unit(单位): mm

Ball Screw Model 滚珠丝杠型号	Travel 行程	Grade 精度	Shaft length 丝杠轴长度	Lead accuracy 导程精度		Total Run-out 全跳动 ↗	Axial play 轴向间隙	Preload Torque 预压扭矩 Nm	Basic Load Rating 基本额定负载 N	
			L ₁	Travel deviation 代表移动量误差 e _p	Variation 波动 V ₃₀₀				Dynamic 额定动负载 Ca	Static 额定静负载 Coa
GSR1020-600R600C5	575	C5	600	±0.030	0.018	0.090	~0.005	-	2100	4000
GSR1020-600R600C7	575	Ct7	600	±0.104	0.050	0.150	~0.020			
GSR1020-600R600C10	575	Ct10	600	±0.420	0.210	0.350	~0.050			

Note) Please designate end-journal profile with your sketch. 注) 轴端的追加加工请结合图纸进行指示。