

GSR1202T | Shaft dia.(轴径) 12 Lead(导程)2mm | C5&Ct7&Ct10 |

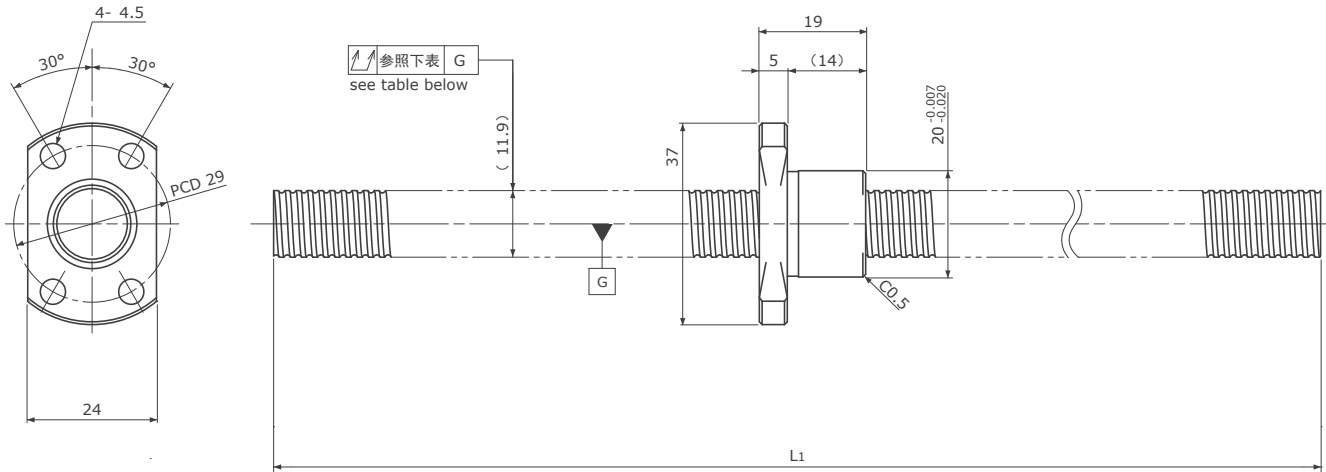

Unit (单位): mm

| Ball Screw Specifications | | 主要技术参数 |
|---------------------------|---------|------------------------|
| Ball size 钢珠直径 | | φ1.2 |
| BCD 钢珠中心直径 | | 12.30 |
| Lead Angle 导程角 | | 2°58′ |
| Number of thread 螺纹条数 | | 1 |
| Thread direction 螺纹旋向 | | Right 右旋 |
| Shaft root dia 丝杠轴底径 | | φ11.0 |
| Number of circuit 循环数 | | 1×3 |
| Material 材质 | Shaft 轴 | S55C |
| | Nut 螺母 | SCM415H |
| Surface hardness 螺纹部表面硬度 | | HRC58~62 (Thread area) |
| Anti-rust treatment 防锈处理 | | Anti-rust oil 防锈油 |

Unit(单位): mm

| Ball Screw Model 滚珠丝杠型号 | Travel 行程 | Grade 精度 | Shaft length 丝杠轴长度 | Lead accuracy 导程精度 | | Total Run-out 全跳动 | Axial play 轴向间隙 | Preload Torque 预压扭矩 Nm | Basic Load Rating 基本额定负载 N | |
|----------------------------|--------------|-------------|-----------------------|---|-------------------------------------|----------------------|--------------------|------------------------------|-------------------------------|------------------------|
| | | | L ₁ | Travel deviation 代表移动量误差 e _p | Variation 波动 V ₃₀₀ | | | | Dynamic 额定动负载 Ca | Static 额定静负载 Coa |
| GSR1202T-600R600C5 | 580 | C5 | 600 | ±0.030 | 0.018 | 0.090 | ~0.005 | - | 1600 | 3700 |
| GSR1202T-600R600C7 | 580 | Ct7 | 600 | ±0.104 | 0.050 | 0.150 | ~0.020 | | | |
| GSR1202T-600R600C10 | 580 | Ct10 | 600 | ±0.420 | 0.210 | 0.350 | ~0.050 | | | |

Note) Please designate end-journal profile with your sketch. 注) 轴端的追加加工请结合图纸进行指示。