

GSR1320A | Shaft dia.(轴径) 13 Lead(导程)20mm | C5&Ct7&Ct10 |

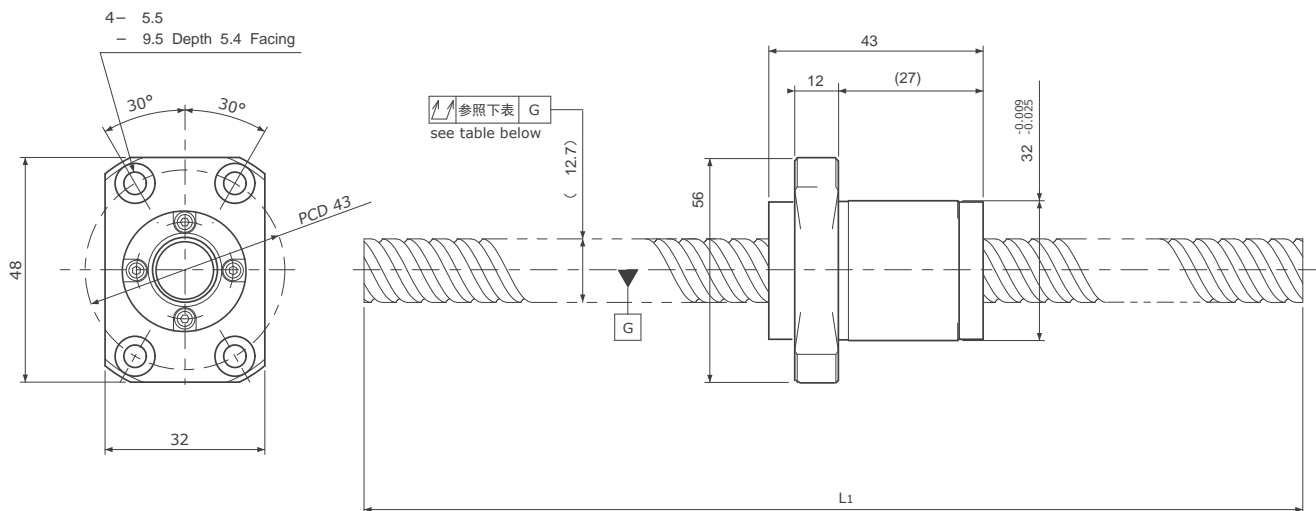

Unit (单位): mm

Ball Screw Specifications		主要技术参数
Ball size 钢珠直径		φ2.381
BCD 钢珠中心直径		13.50
Lead Angle 导程角		25°15′
Number of thread 螺纹条数		2
Thread direction 螺纹旋向		Right 右旋
Shaft root dia 丝杠轴底径		φ11
Number of circuit 循环数		1.65×2
Material 材质	Shaft 轴	S55C
	Nut 螺母	SCM415H
Surface hardness 螺纹部表面硬度		HRC58~62 (Thread area)
Anti-rust treatment 防锈处理		Anti-rust oil 防锈油

Unit(单位): mm

Ball Screw Model 滚珠丝杠型号	Travel 行程	Grade 精度	Shaft length 丝杠轴长度 L_1	Lead accuracy 导程精度		Total Run-out 全跳动 \uparrow	Axial play 轴向间隙	Preload Torque 预压扭矩 Nm	Basic Load Rating 基本额定负载 N	
				Travel deviation 代表移动量误差 e_p	Variation 波动 V_{300}				Dynamic 额定动负载 C_a	Static 额定静负载 C_{0a}
GSR1320A-1200R1200C5	1155	C5	1200	±0.046	0.018	0.150	~0.005	-	5000	10700
GSR1320A-1200R1200C7	1155	Ct7	1200	±0.208	0.050	0.320	~0.020			
GSR1320A-1200R1200C10	1155	Ct10	1200	±0.840	0.210	0.640	~0.050			

Note) Please designate end-journal profile with your sketch. 注) 轴端的追加加工请结合图纸进行指示。