

GSR2005G | Shaft dia.(轴径) 20 Lead(导程)5mm | C5&Ct7&Ct10 |

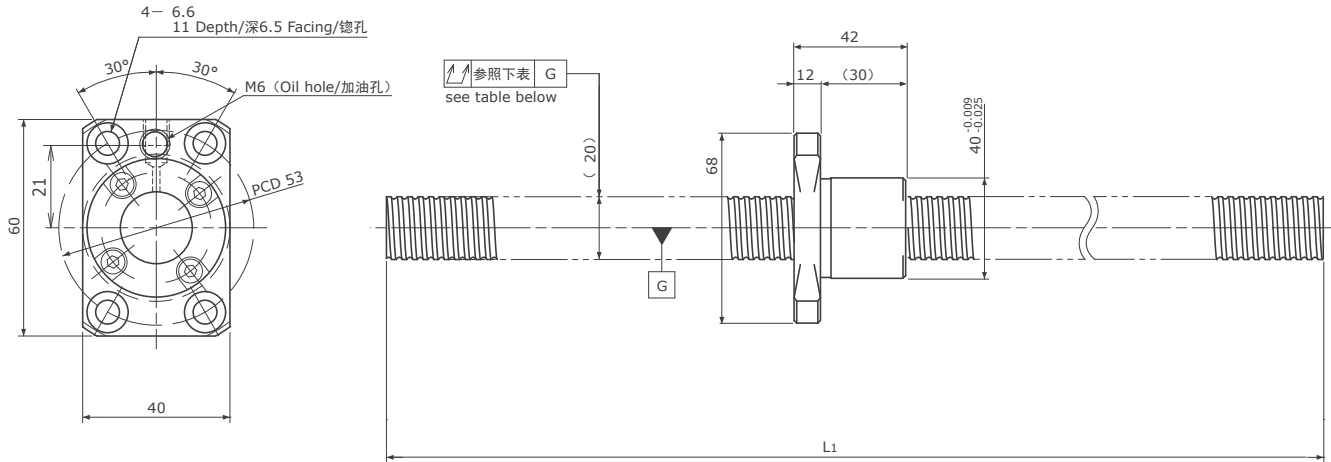

Unit (单位): mm

Ball Screw Specifications		主要技术参数
Ball size	钢珠直径	φ3.175
BCD	钢珠中心直径	21.075
Lead Angle	导程角	4°19′
Number of thread	螺纹条数	1
Thread direction	螺纹旋向	Right 右旋
Shaft root dia	丝杠轴底径	φ17.9
Number of circuit	循环数	3.8×1
Material 材质	Shaft 轴	S55C
	Nut 螺母	SCM415H
Surface hardness 螺纹部表面硬度		HRC58~62 (Thread area)
Anti-rust treatment 防锈处理		Anti-rust oil 防锈油

Unit(单位): mm

Ball Screw Model 滚珠丝杠型号	Travel 行程	Grade 精度	Shaft length 丝杠轴长度	Lead accuracy 导程精度		Total Run-out 全跳动	Axial play 轴向间隙	Preload Torque 预压扭矩 Nm	Basic Load Rating 基本额定负载 N	
			L ₁	Travel deviation 代表移动量误差 e _p	Variation 波动 V ₃₀₀				Dynamic 额定动负载 Ca	Static 额定静负载 Coa
GSR2005G-1200R1200C5	1155	C5	1200	±0.046	0.018	0.150	~0.005	-	9500	22500
GSR2005G-1200R1200C7	1155	Ct7	1200	±0.208	0.050	0.320	~0.020			
GSR2005G-1200R1200C10	1155	Ct10	1200	±0.840	0.210	0.640	~0.050			

Note) Please designate end-journal profile with your sketch. 注) 轴端的追加加工请结合图纸进行指示。