

# GT1004A | Shaft dia.(轴径) 10 Lead(导程)4mm | C5&Ct7 |

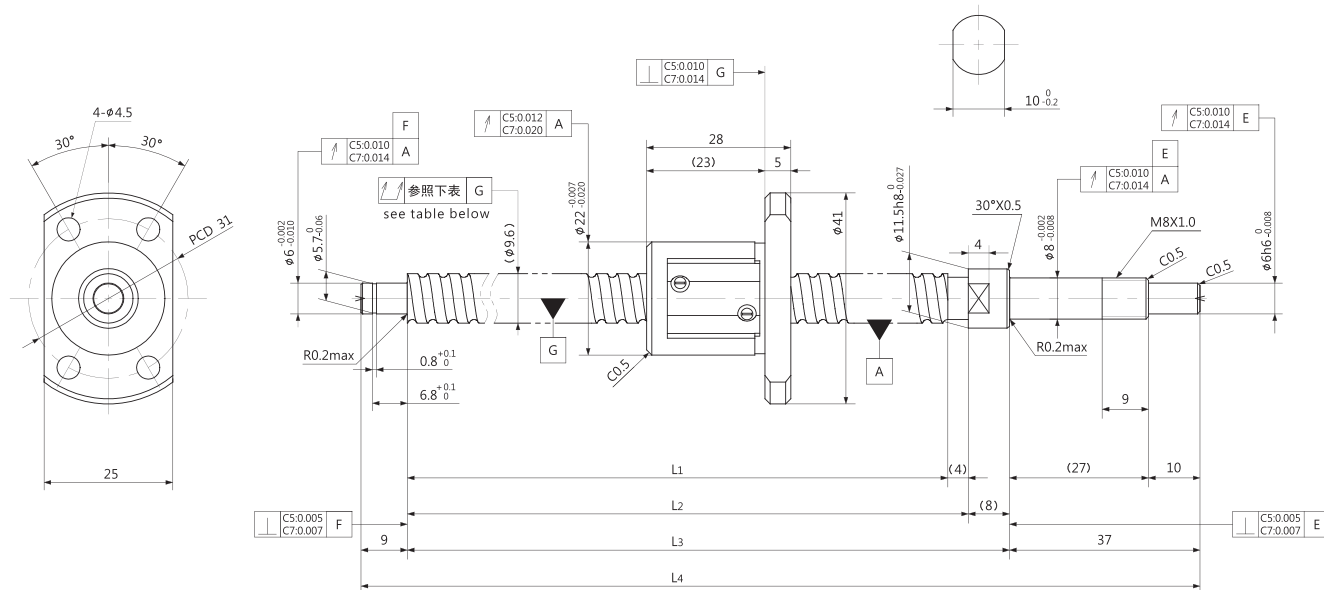

Unit(单位): mm

Ball Screw Specifications		主要技术参数	
Ball size 钢珠直径	φ2.0	BCD 钢珠中心直径	10.30
Lead Angle 导程角	7°03′	Number of thread 螺纹条数	1
Thread direction 螺纹旋向	Right 右旋	Shaft root dia 丝杠轴底径	φ8.2
Number of circuit 循环数	2.7×1	Material 材质	Shaft 轴 S55C+SUS304
			Nut 螺母 SCM415H
Surface hardness 螺纹部表面硬度	HRC58~62 (Thread area)	Anti-rust treatment 防锈处理	Anti-rust oil 防锈油

Unit(单位): mm

Ball Screw Model 滚珠丝杠型号	Travel 行程	Grade 精度	Shaft length 丝杠轴长度				Lead accuracy 导程精度		Total Run-out 全跳动	Axial play 轴向间隙	Basic Load Rating 基本额定负载 N	
			L <sub>1</sub>	L <sub>2</sub>	L <sub>3</sub>	L <sub>4</sub>	Travel deviation 代表移动量误差 e <sub>p</sub>	Variation 波动 V <sub>300</sub>			Dynamic 额定动负载 Ca	Static 额定静负载 Coa
GT1004A-110R168	50	C5	110	114	122	168	±0.020	0.018	0.040	~0.005	3000	5200
		Ct7					±0.050	0.052	0.065	~0.020		
GT1004A-160R218	100	C5	160	164	172	218	±0.020	0.018	0.055	~0.005	3000	5200
		Ct7					±0.028	0.052	0.080	~0.020		
GT1004A-210R268	150	C5	210	214	222	268	±0.023	0.018	0.055	~0.005	3000	5200
		Ct7					±0.036	0.052	0.080	~0.020		
GT1004A-260R318	200	C5	260	264	272	318	±0.023	0.018	0.065	~0.005	3000	5200
		Ct7					±0.045	0.052	0.100	~0.020		
GT1004A-310R368	250	C5	310	314	322	368	±0.023	0.018	0.065	~0.005	3000	5200
		Ct7					±0.054	0.052	0.100	~0.020		

Note) Please designate end-journal profile with your sketch. 注) 轴端的追加加工请结合图纸进行指示。