

GT1005A | Shaft dia.(轴径) 10 Lead(导程)5mm | C5&Ct7 |

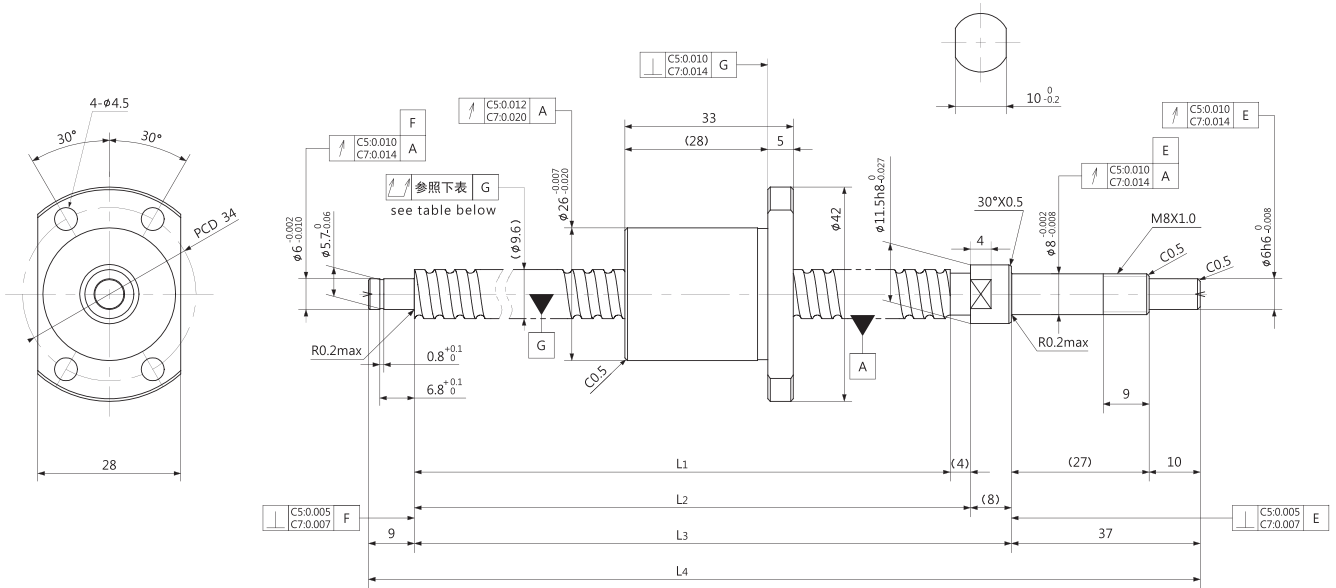

Unit (单位): mm

Ball Screw Specifications		主要技术参数	
Ball size 钢珠直径	φ2.0	BCD 钢珠中心直径	10.30
Lead Angle 导程角	8°47'	Number of thread 螺纹条数	1
Thread direction 螺纹旋向	Right 右旋	Shaft root dia 丝杠轴底径	φ8.2
Number of circuit 循环数	2.7×1	Material 材质	Shaft 轴: S55C+SUS304 Nut 螺母: SCM415H
Surface hardness 螺纹部表面硬度	HRC58~62 (Thread area)	Anti-rust treatment 防锈处理	Anti-rust oil 防锈油

Unit(单位): mm

Ball Screw Model 滚珠丝杠型号	Travel 行程	Grade 精度	Shaft length 丝杠轴长度				Lead accuracy 导程精度		Total Run-out 全跳动	Axial play 轴向间隙	Basic Load Rating 基本额定负载 N	
			L ₁	L ₂	L ₃	L ₄	Travel deviation 代表移动量误差 e _p	Variation 波动 V ₃₀₀			Dynamic 额定动负载 Ca	Static 额定静负载 Coa
GT1005A-167R225	100	C5	167	171	179	225	±0.020	0.018	0.055	~0.005	3000	5200
		Ct7					±0.029	0.052	0.080	~0.020		
GT1005A-217R275	150	C5	217	221	229	275	±0.023	0.018	0.055	~0.005	3000	5200
		Ct7					±0.038	0.052	0.080	~0.020		
GT1005A-267R325	200	C5	267	271	279	325	±0.023	0.018	0.065	~0.005	3000	5200
		Ct7					±0.046	0.052	0.100	~0.020		
GT1005A-317R375	250	C5	317	321	329	375	±0.025	0.018	0.065	~0.005	3000	5200
		Ct7					±0.055	0.052	0.100	~0.020		
GT1005A-367R425	300	C5	367	371	379	425	±0.025	0.018	0.080	~0.005	3000	5200
		Ct7					±0.064	0.052	0.120	~0.020		

Note) Please designate end-journal profile with your sketch. 注) 轴端的追加加工请结合图纸进行指示。