

GT1202A | Shaft dia.(轴径) 12 Lead(导程)2mm | C5&Ct7 |

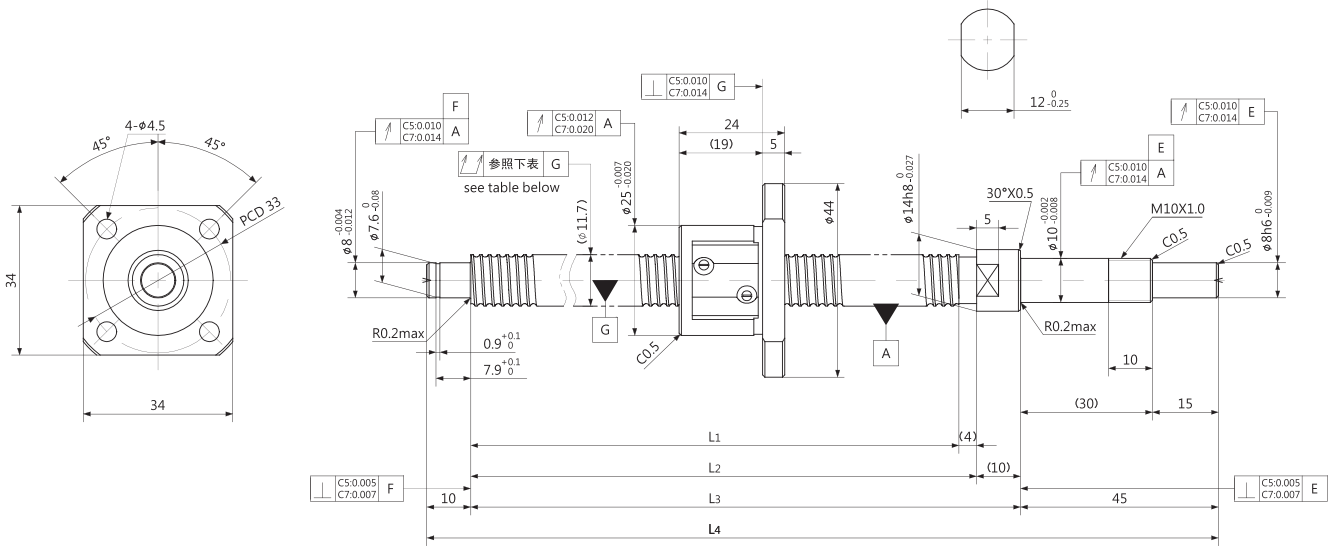

Unit (单位): mm

| Ball Screw Specifications | | 主要技术参数 | |
|---------------------------|------------------------|--------------------------|---|
| Ball size 钢珠直径 | φ1.5875 | BCD 钢珠中心直径 | 12.30 |
| Lead Angle 导程角 | 2°58′ | Number of thread 螺纹条数 | 1 |
| Thread direction 螺纹旋向 | Right 右旋 | Shaft root dia 丝杠轴底径 | φ10.6 |
| Number of circuit 循环数 | 3.7×1 | Material 材质 | Shaft 轴: S55C+SUS304 Nut 螺母: SCM415H |
| Surface hardness 螺纹部表面硬度 | HRC58~62 (Thread area) | Anti-rust treatment 防锈处理 | Anti-rust oil 防锈油 |

Unit(单位): mm

| Ball Screw Model 滚珠丝杠型号 | Travel 行程 | Grade 精度 | Shaft length 丝杠轴长度 | | | | Lead accuracy 导程精度 | | Total Run-out 全跳动 | Axial play 轴向间隙 | Basic Load Rating 基本额定负载 N | |
|----------------------------|--------------|-------------|-----------------------|----------------|----------------|----------------|---|-------------------------------------|----------------------|--------------------|-------------------------------|------------------------|
| | | | L ₁ | L ₂ | L ₃ | L ₄ | Travel deviation 代表移动量误差 e _p | Variation 波动 V ₃₀₀ | | | Dynamic 额定动负载 Ca | Static 额定静负载 Coa |
| GT1202A-85R154 | 50 | C5 | 85 | 89 | 99 | 154 | ±0.018 | 0.018 | 0.040 | ~0.005 | 3000 | 6400 |
| | | Ct7 | | | | | ±0.050 | 0.052 | | | | |
| GT1202A-135R204 | 100 | C5 | 135 | 139 | 149 | 204 | ±0.020 | 0.018 | 0.055 | ~0.005 | 3000 | 6400 |
| | | Ct7 | | | | | ±0.023 | 0.052 | | | | |
| GT1202A-185R254 | 150 | C5 | 185 | 189 | 199 | 254 | ±0.020 | 0.018 | 0.055 | ~0.005 | 3000 | 6400 |
| | | Ct7 | | | | | ±0.032 | 0.052 | | | | |
| GT1202A-235R304 | 200 | C5 | 235 | 239 | 249 | 304 | ±0.023 | 0.018 | 0.055 | ~0.005 | 3000 | 6400 |
| | | Ct7 | | | | | ±0.041 | 0.052 | | | | |
| GT1202A-285R354 | 250 | C5 | 285 | 289 | 299 | 354 | ±0.023 | 0.018 | 0.065 | ~0.005 | 3000 | 6400 |
| | | Ct7 | | | | | ±0.049 | 0.052 | | | | |

Note) Please designate end-journal profile with your sketch. 注) 轴端的追加加工请结合图纸进行指示。