

GT1202K | Shaft dia.(轴径) 12 Lead(导程)2mm | C5&Ct7

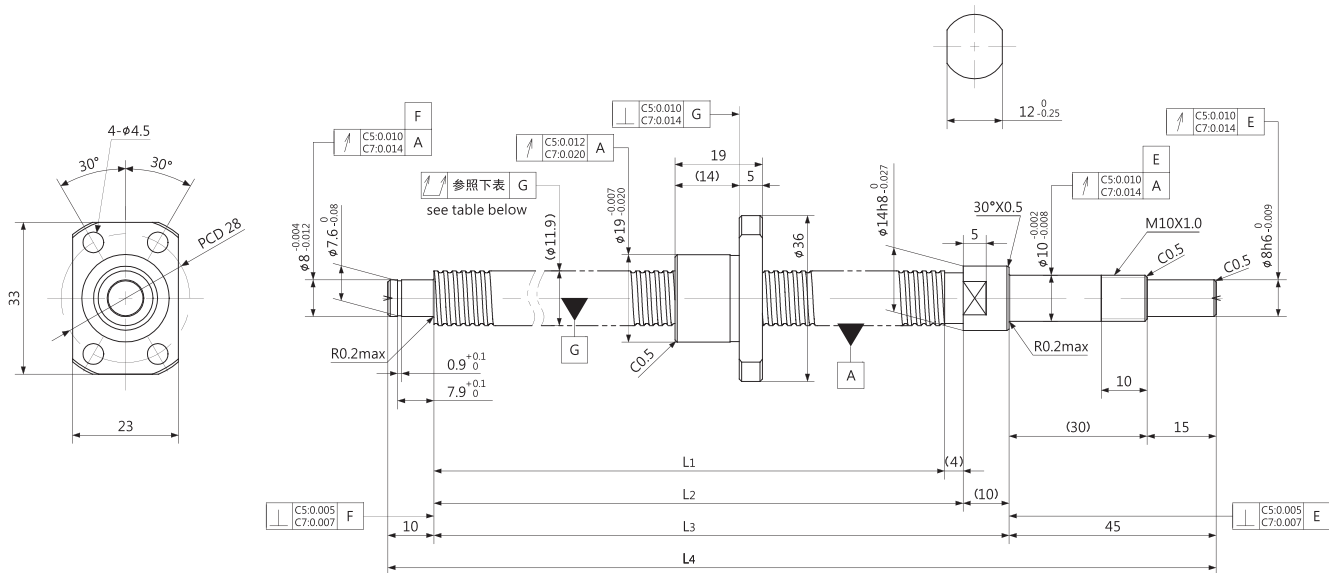

Unit (单位): mm

Ball Screw Specifications		主要技术参数	
Ball size 钢珠直径	φ1.2	BCD 钢珠中心直径	12.30
Lead Angle 导程角	2°58′	Number of thread 螺纹条数	1
Thread direction 螺纹旋向	Right 右旋	Shaft root dia 丝杠轴底径	φ11.0
Number of circuit 循环数	1×3	Material 材质	Shaft 轴: S55C+SUS304 Nut 螺母: SCM415H
Surface hardness 螺纹部表面硬度	HRC58~62 (Thread area)	Anti-rust treatment 防锈处理	Anti-rust oil 防锈油

Unit(单位): mm

Ball Screw Model 滚珠丝杠型号	Travel 行程	Grade 精度	Shaft length 丝杠轴长度				Lead accuracy 导程精度		Total Run-out 全跳动	Axial play 轴向间隙	Basic Load Rating 基本额定负载 N	
			L ₁	L ₂	L ₃	L ₄	Travel deviation 代表移动量误差 e _p	Variation 波动 V ₃₀₀			Dynamic 额定动负载 Ca	Static 额定静负载 Coa
GT1202K-85R154	50	C5	85	89	99	154	±0.018	0.018	0.040	~0.005	1600	3700
		Ct7					±0.050	0.052	0.065	~0.020		
GT1202K-135R204	100	C5	135	139	149	204	±0.020	0.018	0.055	~0.005	1600	3700
		Ct7					±0.023	0.052	0.080	~0.020		
GT1202K-185R254	150	C5	185	189	199	254	±0.020	0.018	0.055	~0.005	1600	3700
		Ct7					±0.032	0.052	0.080	~0.020		
GT1202K-235R304	200	C5	235	239	249	304	±0.023	0.018	0.055	~0.005	1600	3700
		Ct7					±0.041	0.052	0.080	~0.020		
GT1202K-285R354	250	C5	285	289	299	354	±0.023	0.018	0.065	~0.005	1600	3700
		Ct7					±0.049	0.052	0.100	~0.020		

Note) Please designate end-journal profile with your sketch. 注) 轴端的追加加工请结合图纸进行指示。