

GT1402 | Shaft dia.(轴径) 14 Lead(导程)2mm | C5&Ct7 |

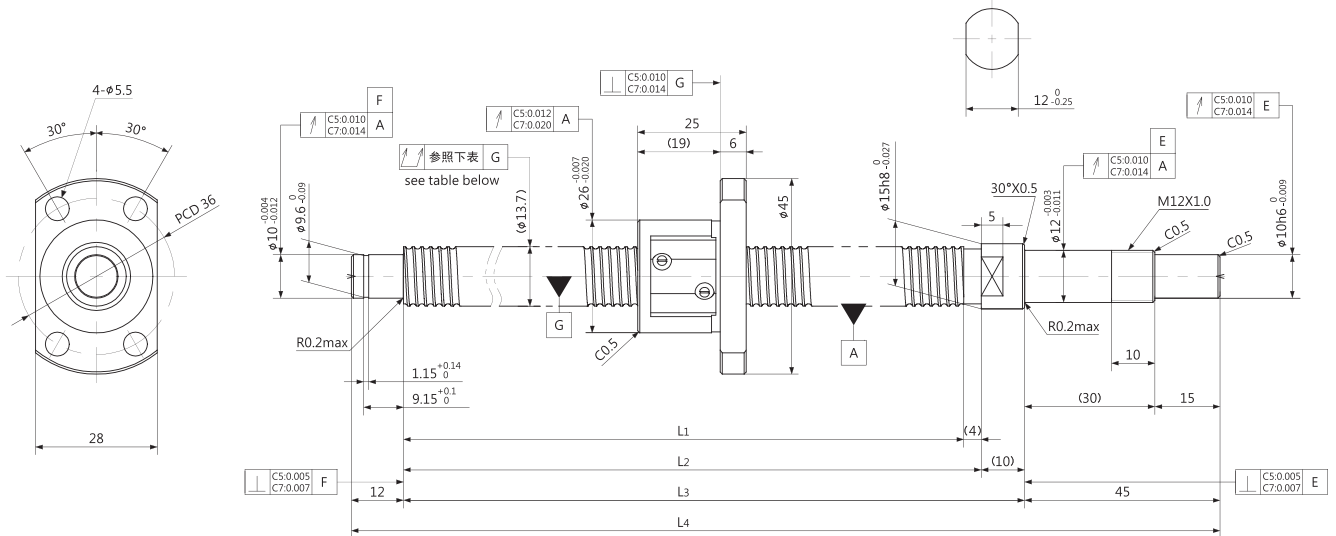

Unit (单位): mm

Ball Screw Specifications		主要技术参数	
Ball size 钢球直径	$\phi 1.5875$	BCD 钢球中心直径	14.30
Lead Angle 导程角	$2^{\circ}33'$	Number of thread 螺纹条数	1
Thread direction 螺纹旋向	Right 右旋	Shaft root dia 丝杠轴底径	$\phi 12.6$
Number of circuit 循环数	3.7×1	Material 材质	Shaft 轴: S55C+SUS304 Nut 螺母: SCM415H
Surface hardness 螺纹部表面硬度	HRC58~62 (Thread area)	Anti-rust treatment 防锈处理	Anti-rust oil 防锈油

Unit(单位): mm

Ball Screw Model 滚珠丝杠型号	Travel 行程	Grade 精度	Shaft length 丝杠轴长度				Lead accuracy 导程精度		Total Run-out 全跳动	Axial play 轴向间隙	Basic Load Rating 基本额定负载 N	
			L ₁	L ₂	L ₃	L ₄	Travel deviation 代表移动量误差 e _p	Variation 波动 V ₃₀₀			Dynamic 额定动负载 Ca	Static 额定静负载 Coa
GT1402-85R156	50	C5	85	89	99	156	± 0.018	0.018	0.040	~0.005	3200	5000
		Ct7					± 0.050	0.052	0.060	~0.020		
GT1402-135R206	100	C5	135	139	149	206	± 0.020	0.018	0.045	~0.005	3200	5000
		Ct7					± 0.023	0.052	0.070	~0.020		
GT1402-185R256	150	C5	185	189	199	256	± 0.020	0.018	0.045	~0.005	3200	5000
		Ct7					± 0.032	0.052	0.070	~0.020		
GT1402-235R306	200	C5	235	239	249	306	± 0.023	0.018	0.045	~0.005	3200	5000
		Ct7					± 0.041	0.052	0.070	~0.020		
GT1402-335R406	300	C5	335	339	349	406	± 0.025	0.018	0.060	~0.005	3200	5000
		Ct7					± 0.058	0.052	0.095	~0.020		

Note) Please designate end-journal profile with your sketch. 注) 轴端的追加加工请结合图纸进行指示。