

Unit (单位): mm

Ball Screw Specifications		主要技术参数	
Ball size 钢球直径	φ3.175	BCD 钢球中心直径	15.50
Lead Angle 导程角	5°41′	Number of thread 螺纹条数	1
Thread direction 螺纹旋向	Right 右旋	Shaft root dia 丝杠轴底径	φ12.2
Number of circuit 循环数	3.7×1	Material 材质	Shaft 轴: S55C Nut 螺母: SCM415H
Surface hardness 螺纹部表面硬度	HRC58~62 (Thread area)	Anti-rust treatment 防锈处理	Anti-rust oil 防锈油

Unit(单位): mm

Ball Screw Model 滚珠丝杠型号	Travel 行程	Grade 精度	Shaft length 丝杠轴长度		Lead accuracy 导程精度		Total Run-out 全跳动	Axial play 轴向间隙	Basic Load Rating 基本额定负载 N	
			L ₁	L ₂	Travel deviation 代表移动量误差 e _p	Variation 波动 V ₃₀₀			Dynamic 额定动负载 Ca	Static 额定静负载 Coa
GT1505-239R296	150	C5	239	296	±0.023	0.018	0.045	~0.005	8900	17000
		Ct7			±0.041	0.052	0.070	~0.020		
GT1505-289R346	200	C5	289	346	±0.023	0.018	0.055	~0.005	8900	17000
		Ct7			±0.050	0.052	0.080	~0.020		
GT1505-339R396	250	C5	339	396	±0.025	0.018	0.055	~0.005	8900	17000
		Ct7			±0.059	0.052	0.080	~0.020		
GT1505-389R446	300	C5	389	446	±0.025	0.018	0.060	~0.005	8900	17000
		Ct7			±0.067	0.052	0.095	~0.020		
GT1505-439R496	350	C5	439	496	±0.027	0.018	0.060	~0.005	8900	17000
		Ct7			±0.076	0.052	0.095	~0.020		
GT1505-489R546	400	C5	489	546	±0.027	0.018	0.075	~0.005	8900	17000
		Ct7			±0.085	0.052	0.110	~0.020		

Note) Please designate end-journal profile with your sketch. 注) 轴端的追加加工请结合图纸进行指示。

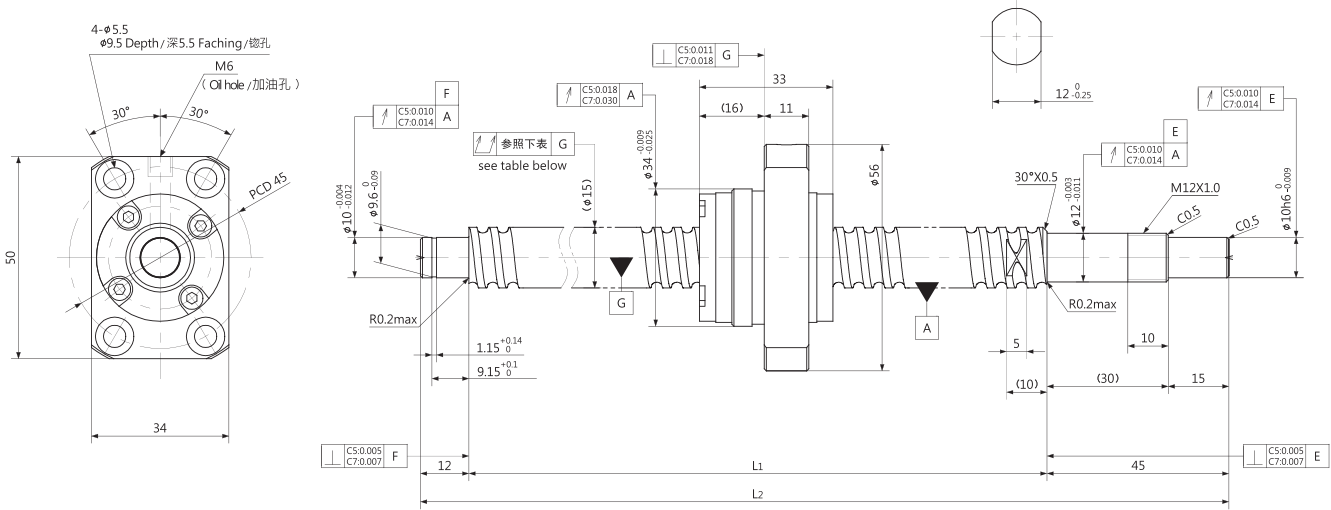

Unit (单位): mm

Ball Screw Specifications		主要技术参数	
Ball size 钢珠直径	φ3.175	BCD 钢珠中心直径	15.50
Lead Angle 导程角	5°41'	Number of thread 螺纹条数	1
Thread direction 螺纹旋向	Right 右旋	Shaft root dia 丝杠轴底径	φ12.2
Number of circuit 循环数	3.7×1	Material 材质	Shaft 轴 S55C
			Nut 螺母 SCM415H
Surface hardness 螺纹部表面硬度	HRC58~62 (Thread area)	Anti-rust treatment 防锈处理	Anti-rust oil 防锈油

Unit(单位): mm

Ball Screw Model 滚珠丝杠型号	Travel 行程	Grade 精度	Shaft length 丝杠轴长度		Lead accuracy 导程精度		Total Run-out 全跳动	Axial play 轴向间隙	Basic Load Rating 基本额定负载 N	
			L ₁	L ₂	Travel deviation 代表移动量误差 e _p	Variation 波动 V ₃₀₀			Dynamic 额定动负载 Ca	Static 额定静负载 Coa
GT1505-539R596	450	C5	539	596	±0.030	0.018	0.075	~0.005	8900	17000
		Ct7			±0.093	0.052	0.110	~0.020		
GT1505-589R646	500	C5	589	646	±0.030	0.018	0.090	~0.005	8900	17000
		Ct7			±0.102	0.052	0.140	~0.020		
GT1505-639R696	550	C5	639	696	±0.035	0.018	0.090	~0.005	8900	17000
		Ct7			±0.111	0.052	0.140	~0.020		
GT1505-689R746	600	C5	689	746	±0.035	0.018	0.090	~0.005	8900	17000
		Ct7			±0.119	0.052	0.140	~0.020		
GT1505-789R846	700	C5	789	846	±0.035	0.018	0.120	~0.005	8900	17000
		Ct7			±0.137	0.052	0.170	~0.020		
GT1505-889R946	800	C5	889	946	±0.040	0.018	0.120	~0.005	8900	17000
		Ct7			±0.154	0.052	0.170	~0.020		

Note) Please designate end-journal profile with your sketch. 注) 轴端的追加加工请结合图纸进行指示。