

GT1520T

Shaft dia.(轴径) 15

Lead(导程)20mm

C5&Ct7

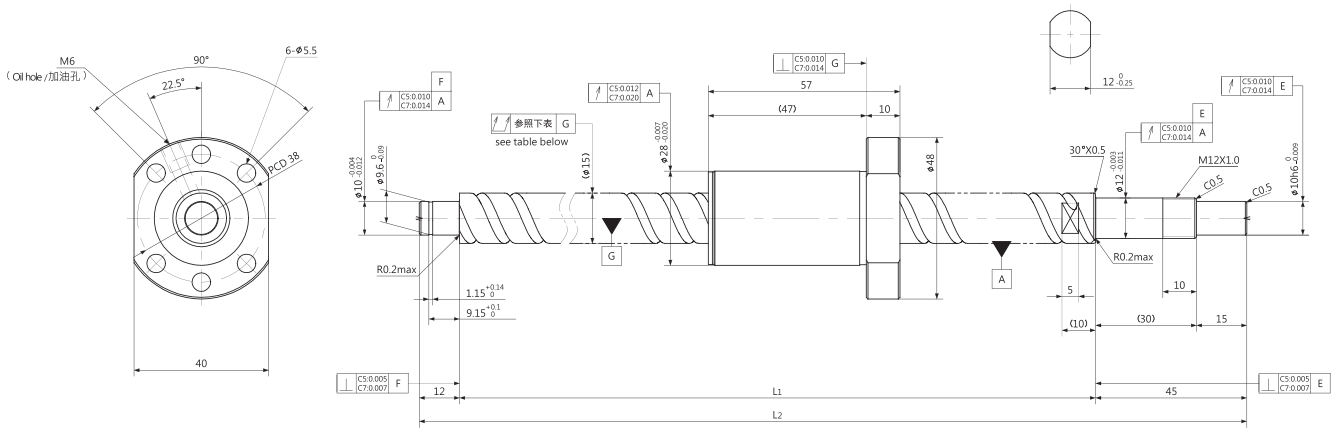

Unit(单位): mm

Ball Screw Specifications		主要技术参数	
Ball size 钢球直径	φ2.778	BCD 钢球中心直径	15.75
Lead Angle 导程角	22°01′	Number of thread 螺纹条数	1
Thread direction 螺纹旋向	Right 右旋	Shaft root dia 丝杠轴底径	φ13.0
Number of circuit 循环数	1.8×1	Material 材质	Shaft 轴: S55C Nut 螺母: SCM415H
Surface hardness 螺纹部表面硬度	HRC58~62 (Thread area)	Anti-rust treatment 防锈处理	Anti-rust oil 防锈油

Unit(单位): mm

Ball Screw Model 滚珠丝杠型号	Travel 行程	Grade 精度	Shaft length 丝杠轴长度		Lead accuracy 导程精度		Total Run-out 全跳动	Axial play 轴向间隙	Basic Load Rating 基本额定负载 N	
			L ₁	L ₂	Travel deviation 代表移动量误差 e _p	Variation 波动 V ₃₀₀			Dynamic 额定动负载 Ca	Static 额定静负载 Coa
GT1520T-536R593	450	C5	539	596	±0.030	0.018	0.075	~0.005	3600	6600
		Ct7			±0.093	0.052				
GT1520T-586R643	500	C5	589	646	±0.030	0.018	0.090	~0.005	3600	6600
		Ct7			±0.102	0.052				
GT1520T-636R693	550	C5	639	696	±0.035	0.018	0.090	~0.005	3600	6600
		Ct7			±0.111	0.052				
GT1520T-686R743	600	C5	689	746	±0.035	0.018	0.090	~0.005	3600	6600
		Ct7			±0.119	0.052				
GT1520T-786R843	700	C5	789	846	±0.035	0.018	0.120	~0.005	3600	6600
		Ct7			±0.137	0.052				
GT1520T-886R943	800	C5	889	946	±0.040	0.018	0.120	~0.005	3600	6600
		Ct7			±0.154	0.052				

Note) Please designate end-journal profile with your sketch. 注) 轴端的追加加工请结合图纸进行指示。