

SXM1002 | Shaft dia.(轴径) 10 Lead(导程)2mm | C3&C5 |

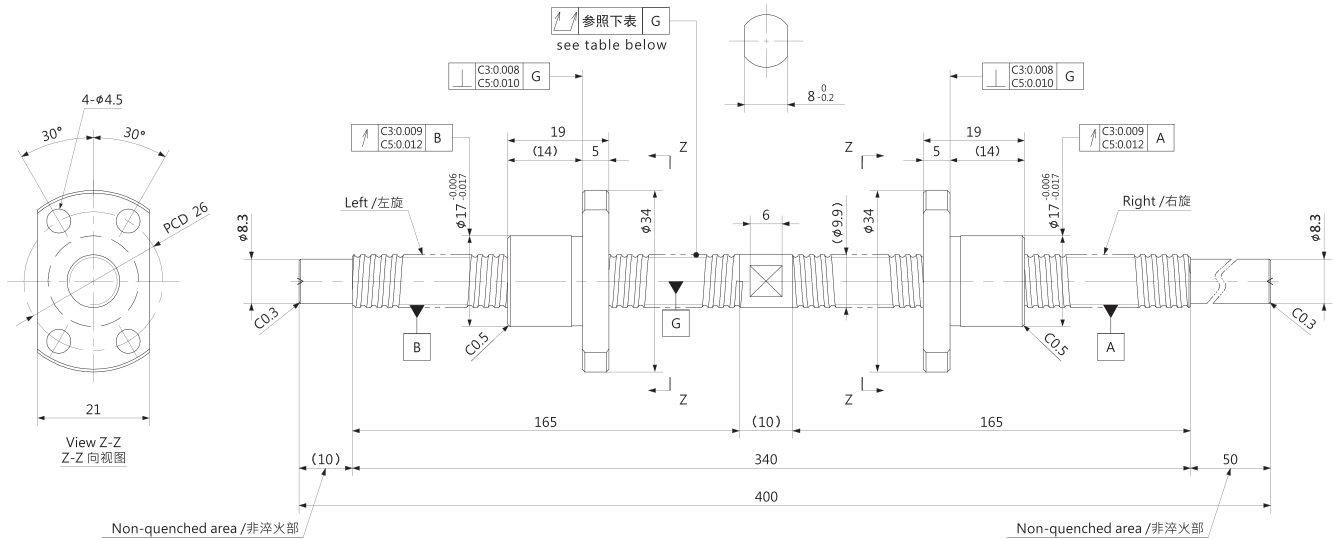

Unit (单位): mm

Ball Screw Specifications		主要技术参数
Ball size	钢球直径	φ1.2
BCD	钢球中心直径	10.30
Lead Angle	导程角	3°32'
Number of thread	螺纹条数	1
Thread direction	螺纹旋向	Right 右旋
Shaft root dia	丝杠轴底径	φ9.0
Number of circuit	循环数	1×3
Material 材质	Shaft 轴	S55C
	Nut 螺母	SCM415H
Surface hardness 螺纹部表面硬度		HRC58~62 (Thread area)
Anti-rust treatment 防锈处理		Anti-rust oil 防锈油

Unit(单位): mm

Ball Screw Model 滚珠丝杠型号	Travel 行程	Grade 精度	Lead accuracy 导程精度		Total Run-out 全跳动	Axial play 轴向间隙	Preload Torque 预压扭矩 Nm	Basic Load Rating 基本额定负载 N	
			Travel deviation 代表移动量误差 e _p	Variation 波动 V ₃₀₀				Dynamic 额定动负载 Ca	Static 额定静负载 Coa
SXM1002-165L165R400C3	145	C3	±0.010	0.008	0.050	0	~0.025	1450	3000
SXM1002-165L165R400C5	145	C5	±0.020	0.018	0.065	~0.005	-	1450	3000

Note) Please designate end-journal profile with your sketch. (注) 轴端的追加加工请结合图纸进行指示。