

# TXM0402 | Shaft dia.(轴径) 4 | Lead(导程)2mm | C3&C5 |

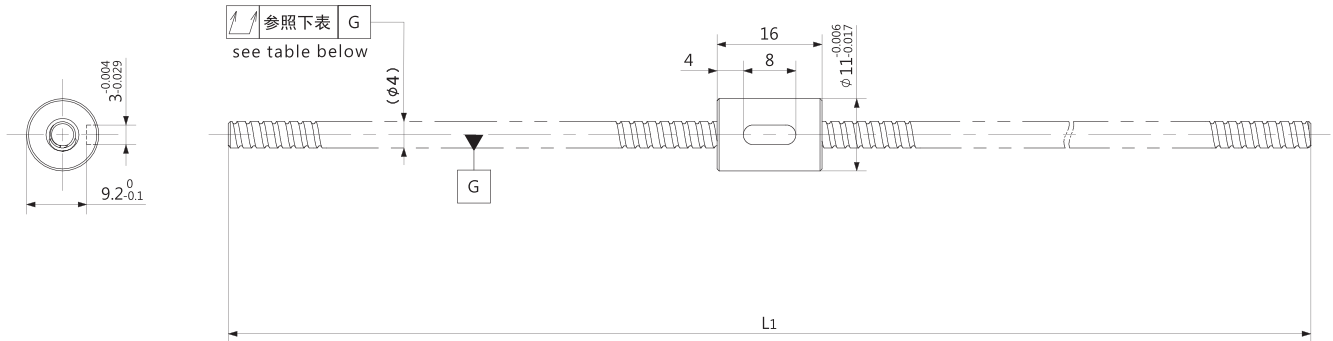

Unit (单位): mm

| Ball Screw Specifications |         | 主要技术参数                    |
|---------------------------|---------|---------------------------|
| Ball size 钢珠直径            |         | φ0.8                      |
| BCD 钢珠中心直径                |         | 4.15                      |
| Lead Angle 导程角            |         | 8°43′                     |
| Number of thread 螺纹条数     |         | 1                         |
| Thread direction 螺纹旋向     |         | Right 右旋                  |
| Shaft root dia 丝杠轴底径      |         | φ3.3                      |
| Number of circuit 循环数     |         | 2.7×1                     |
| Material 材质               | Shaft 轴 | S55C                      |
|                           | Nut 螺母  | SCM415H                   |
| Surface hardness 螺纹部表面硬度  |         | HRC58~62<br>(Thread area) |
| Anti-rust treatment 防锈处理  |         | Anti-rust oil<br>防锈油      |

Unit(单位) :mm

| Ball Screw Model<br>滚珠丝杠型号 | Travel<br>行程 | Grade<br>精度 | Shaft length<br>丝杠轴长度 | Lead accuracy<br>导程精度                         |                                     | Total Run-out<br>全跳动 | Axial play<br>轴向间隙                | Preload Torque<br>预压扭矩<br>Nm | Basic Load Rating<br>基本额定负载 N |                        |
|----------------------------|--------------|-------------|-----------------------|---|-------------------------------------|----------------------|-----------------------------------|------------------------------|-------------------------------|------------------------|
|                            |              |             | L <sub>1</sub>        | Travel deviation<br>代表移动量误差<br>e <sub>p</sub> | Variation<br>波动<br>V <sub>300</sub> |                      |                                   |                              | Dynamic<br>额定动负载<br>Ca        | Static<br>额定静负载<br>Coa |
| TXM0402-044R084            | 62           | C3          | 84                    | ±0.008  | 0.008                               | 0.035                | 0<br>Spacer ball<br>间隔钢珠<br>(1:1) | ~0.004                       | 260                           | 290                    |
| TXM0402-064R104            | 82           |             | 104                   | ±0.008  |                                     |                      |                                   |                              |                               |                        |
| TXM0402-094R134            | 112          |             | 134                   | ±0.008  |                                     |                      |                                   |                              |                               |                        |
| TXM0402-044R084            | 62           | C5          | 84                    | ±0.018  | 0.018                               | 0.090                | ~0.005                            | -                            | 420                           | 570                    |
| TXM0402-064R104            | 82           |             | 104                   | ±0.018  |                                     |                      |                                   |                              |                               |                        |
| TXM0402-094R134            | 112          |             | 134                   | ±0.018  |                                     |                      |                                   |                              |                               |                        |

Note) Please designate end-journal profile with your sketch. 注) 轴端的追加加工请结合图纸进行指示。