

TXM0802B | Shaft dia.(轴径) 8 Lead(导程)2mm | C3&C5 |

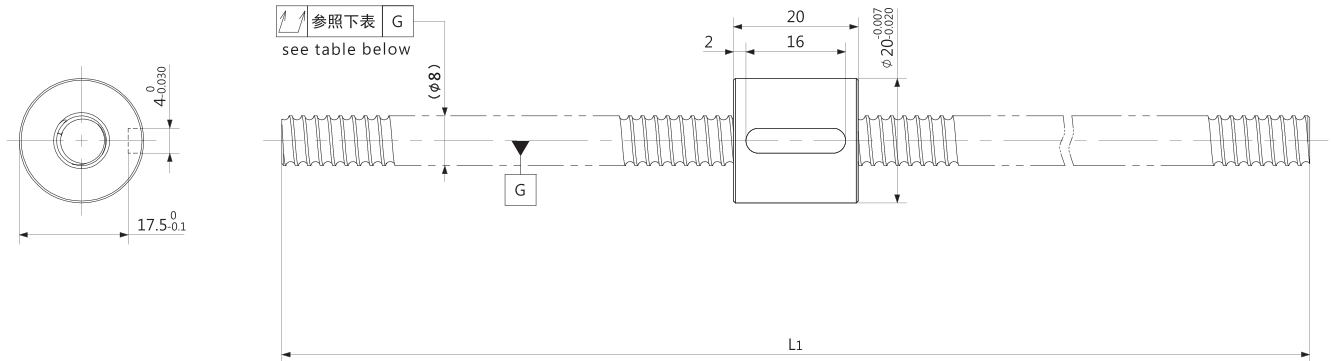

Unit (单位): mm

Ball Screw Specifications		主要技术参数
Ball size 钢珠直径		φ1.5875
BCD 钢珠中心直径		8.30
Lead Angle 导程角		4°23′
Number of thread 螺纹条数		1
Thread direction 螺纹旋向		Right 右旋
Shaft root dia 丝杠轴底径		φ6.6
Number of circuit 循环数		3.7×1
Material 材质	Shaft 轴	S55C
	Nut 螺母	SCM415H
Surface hardness 螺纹部表面硬度		HRC58~62 (Thread area)
Anti-rust treatment 防锈处理		Anti-rust oil 防锈油

Unit(单位): mm

Ball Screw Model 滚珠丝杠型号	Travel 行程	Grade 精度	Shaft length 丝杠轴长度	Lead accuracy 导程精度		Total Run-out 全跳动	Axial play 轴向间隙	Preload Torque 预压扭矩 Nm	Basic Load Rating 基本额定负载 N	
			L ₁	Travel deviation 代表移动量误差 e _p	Variation 波动 V ₃₀₀				Dynamic 额定动负载 Ca	Static 额定静负载 Coa
TXM0802B-074R124	100.5	C3	124	±0.008	0.008	0.060	0 Spacer ball 间隔钢珠 (1:1)	0.004~0.020	1550	2100
TXM0802B-104R154	130.5		154	±0.010						
TXM0802B-134R184	160.5		184	±0.010						
TXM0802B-184R234	210.5		234	±0.010						
TXM0802B-074R124	100.5	C5	124	±0.018	0.018	0.090	~0.005	-	2400	4100
TXM0802B-104R154	130.5		154	±0.020						
TXM0802B-134R184	160.5		184	±0.020						
TXM0802B-184R234	210.5		234	±0.020						

Note) Please designate end-journal profile with your sketch. 注) 轴端的追加加工请结合图纸进行指示。