

# TXM0804 | Shaft dia.(轴径) 8 | Lead(导程)4mm | C3&C5 |

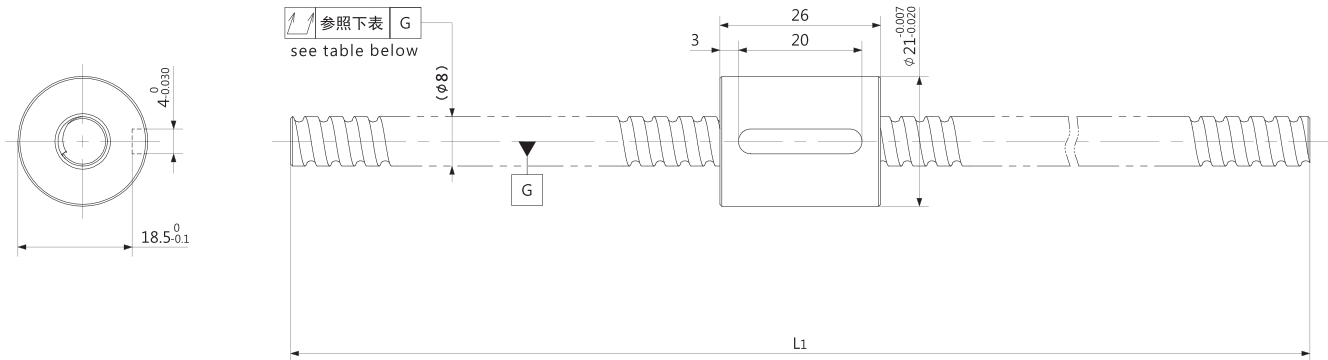

Unit (单位): mm

Ball Screw Specifications		主要技术参数
Ball size 钢球直径		φ2.0
BCD 钢球中心直径		8.30
Lead Angle 导程角		8°43′
Number of thread 螺纹条数		1
Thread direction 螺纹旋向		Right 右旋
Shaft root dia 丝杠轴底径		φ6.2
Number of circuit 循环数		2.7×1
Material 材质	Shaft 轴	S55C
	Nut 螺母	SCM415H
Surface hardness 螺纹部表面硬度		HRC58~62 (Thread area)
Anti-rust treatment 防锈处理		Anti-rust oil 防锈油

Unit(单位): mm

Ball Screw Model 滚珠丝杠型号	Travel 行程	Grade 精度	Shaft length 丝杠轴长度	Lead accuracy 导程精度		Total Run-out 全跳动	Axial play 轴向间隙	Preload Torque 预压扭矩 Nm	Basic Load Rating 基本额定负载 N	
			L <sub>1</sub>	Travel deviation 代表移动量误差 e <sub>p</sub>	Variation 波动 V <sub>300</sub>				Dynamic 额定动负载 Ca	Static 额定静负载 Coa
TXM0804-074R124	91	C3	124	±0.008	0.008	0.060	0 Spacer ball 间隔钢珠 (1:1)	~0.015	1650	2100
TXM0804-104R154	121		154	±0.010						
TXM0804-134R184	151		184	±0.010						
TXM0804-184R234	201		234	±0.010						
TXM0804-074R124	91	C5	124	±0.018	0.018	0.090	~0.005	-	2600	4200
TXM0804-104R154	121		154	±0.020						
TXM0804-134R184	151		184	±0.023						
TXM0804-184R234	201		234	±0.020						

Note) Please designate end-journal profile with your sketch. 注) 轴端的追加加工请结合图纸进行指示。