

TXM1202.5 | Shaft dia.(轴径) 12 Lead(导程)2.5mm | C3&C5 |

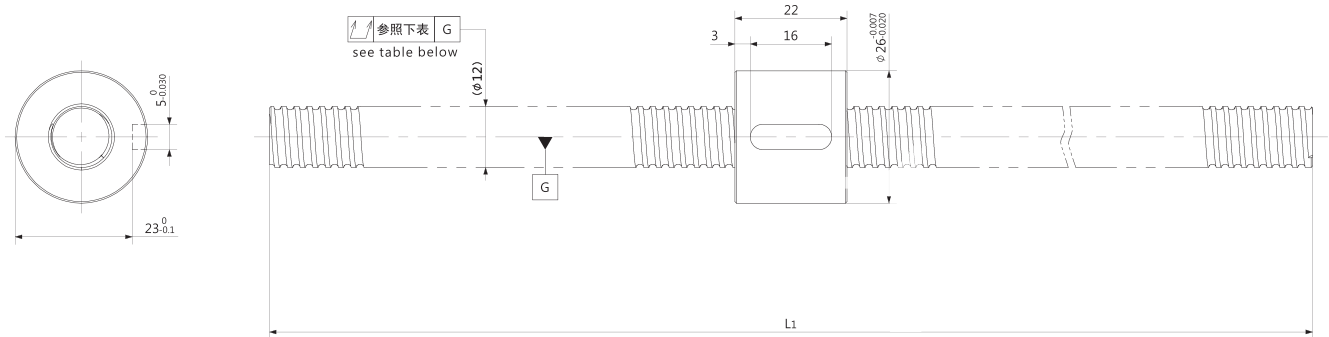

Unit (单位): mm

Ball Screw Specifications		主要技术参数
Ball size	钢珠直径	φ1.5875
BCD	钢珠中心直径	12.30
Lead Angle	导程角	3°42′
Number of thread	螺纹条数	1
Thread direction	螺纹旋向	Right 右旋
Shaft root dia	丝杠轴底径	φ10.6
Number of circuit	循环数	3.7×1
Material 材质	Shaft 轴	S55C
	Nut 螺母	SCM415H
Surface hardness 螺纹部表面硬度		HRC58~62 (Thread area)
Anti-rust treatment 防锈处理		Anti-rust oil 防锈油

Unit(单位) :mm

Ball Screw Model 滚珠丝杠型号	Travel 行程	Grade 精度	Shaft length 丝杠轴长度	Lead accuracy 导程精度		Total Run-out 全跳动 ↗	Axial play 轴向间隙 0 Spacer ball 间隔钢珠 (1:1)	Preload Torque 预压扭矩 Nm	Basic Load Rating 基本额定负载 N	
			L ₁	Travel deviation 代表移动量误差 e _p	Variation 波动 V ₃₀₀				Dynamic 额定动负载 Ca	Static 额定静负载 Coa
TXM1202.5-510R510C3	490	C3	510	±0.015	0.008	0.065	—	—	1850	3200
TXM1202.5-600R600C5	580	C5	600	±0.030	0.018	0.090	~0.005	—	3000	6400

Note) Please designate end-journal profile with your sketch. 注) 轴端的追加加工请结合图纸进行指示。