

TXR1006 | Shaft dia.(轴径) 10 Lead(导程)6mm | C5&Ct7C10 |

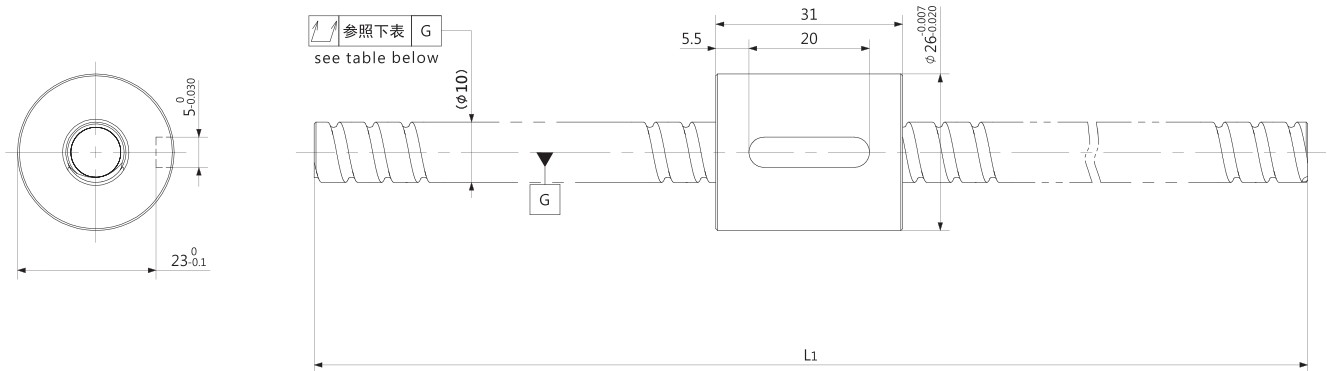

Unit (单位): mm

Ball Screw Specifications		主要技术参数
Ball size	钢珠直径	φ2.0
BCD	钢珠中心直径	10.30
Lead Angle	导程角	10°30′
Number of thread	螺纹条数	1
Thread direction	螺纹旋向	Right 右旋
Shaft root dia	丝杠轴底径	φ8.2
Number of circuit	循环数	2.7×1
Material 材质	Shaft 轴	S55C
	Nut 螺母	SCM415H
Surface hardness 螺纹部表面硬度		HRC58~62 (Thread area)
Anti-rust treatment 防锈处理		Anti-rust oil 防锈油

Unit(单位): mm

Ball Screw Model 滚珠丝杠型号	Travel 行程	Grade 精度	Shaft length 丝杠轴长度	Lead accuracy 导程精度		Total Run-out 全跳动	Axial play 轴向间隙	Basic Load Rating 基本额定负载 N	
			L ₁	Travel deviation 代表移动量误差 e _p	Variation 波动 V ₃₀₀			Dynamic 额定动负载 Ca	Static 额定静负载 Coa
TXR1006-1200R1200C5	1170	C5	1200	±0.046	0.018	0.150	~0.005	3000	5000
TXR1006-1200R1200C7		Ct7		±0.208	0.052	0.320	~0.020		
TXR1006-1200R1200C10		Ct10		±0.840	0.210	0.640	~0.050		

Note) Please designate end-journal profile with your sketch. (注) 轴端的追加加工请结合图纸进行指示。